

Introduction to Chance Constraint Optimization

5-7, October 2022, Ilmenau

Chance Constrained Process Optimization and Control under Uncertainty

Pu Li

pu.li@tu-ilmenau.de

www.tu-ilmenau.de/prozessoptimierung

Group of Process Optimization
Institute for Automation and Systems Engineering
Technische Universität Ilmenau



- 1. Introduction and Overview**
- 2. Optimization Problems under Uncertainty**
- 3. Chance Constrained Linear Process Optimization**
- 4. Chance Constrained Model Predictive Control**
- 5. Chance Constrained Nonlinear Optimization and Control**
- 6. Future Challenges**

1. Introduction and Overview

- ▶ **Motivation**
- ▶ **Deterministic approaches**
- ▶ **Stochastic approaches**
- ▶ **Problem relaxation**

▶ **Uncertain Operating Conditions:**

- Future product demands, product specifications
- Future supply of raw materials, feed flow and concentration
- Availability of utilities (power, steam, ...)
- Atmospheric temperature and pressure

▶ **Uncertain Model parameters:**

- Kinetic parameters
- Phase equilibrium parameters
- Operation-dependent parameters

▶ **Properties of Optimization under Uncertainty:**

- Design and operation
- Profit maximization / cost minimization
- Meet the operating constraints
- Consider a future time horizon (hours, days, weeks, ...)
- Decision making without knowledge of exact values of some variables

University

- ▶ Development of **deterministic** optimization approaches
 - LP, NLP
 - MILP, MINLP
 - DNLP, MIDO
- ▶ Applications have been mostly based on **theoretical** models
 - fixed model parameters
 - fixed operating conditions
 - test on labor or pilot plants

Industry

- ▶ Complex processes
- ▶ Models are often not available
- ▶ Operating conditions change all the time
- ▶ Standard software with deterministic solution approaches



Deterministic results are difficult to transfer!



Optimization under Uncertainty

▶ **Using the Expected Value**

- Base-Case-Analysis
- Too optimistic decisions (aggressive strategy)
- Violating the constraints with a 50% probability

▶ **Using the Bound Values**

- Worst-Case-Analysis
- Conservative decisions (no risks, safety with priority)
- Very low profit

▶ **Scenario Analysis**

- Study more scenarios
- Relative robust decisions
- Not all cases can be considered

Problem formulation:

$$\begin{aligned} \min \quad & f(\mathbf{x}, \mathbf{u}, \xi) && \text{with} && \mathbf{x} \in \mathcal{R}^n \\ \text{s.t.} \quad & \mathbf{g}(\dot{\mathbf{x}}, \mathbf{x}, \mathbf{u}, \xi) = \mathbf{0}, \quad \mathbf{x}(0) = \mathbf{x}_0 && && \mathbf{u} \in \mathcal{R}^l \\ & \mathbf{h}(\dot{\mathbf{x}}, \mathbf{x}, \mathbf{u}, \xi) \geq \mathbf{0}, \quad \xi \sim \mathbf{N}(\boldsymbol{\mu}, \boldsymbol{\Sigma}) && && \xi \in \mathcal{R}^m \end{aligned}$$

Due to the existence of the random variables ξ , the problem cannot be solved directly with the available deterministic optimization methods.

Special treatments (transformation) will be needed to transfer the problem to an equivalent deterministic problem (so-called relaxation).

Deterministic formulation:

$$\begin{aligned} \min \quad & f(\mathbf{x}, \mathbf{u}, \bar{\xi}) \\ \text{s.t.} \quad & \mathbf{g}(\dot{\mathbf{x}}, \mathbf{x}, \mathbf{u}, \bar{\xi}) = \mathbf{0}, \quad \mathbf{x}(0) = \mathbf{x}_0 \\ & \mathbf{h}(\dot{\mathbf{x}}, \mathbf{x}, \mathbf{u}, \bar{\xi}) \geq \mathbf{0} \end{aligned}$$

- $\bar{\xi}$ is considered as fixed parameter in the problem.
- \mathbf{x}, \mathbf{u} will be solved by a deterministic method.
- But in the reality $\xi \neq \bar{\xi}$, i.e. $\mathbf{h}(\dot{\mathbf{x}}, \mathbf{x}, \mathbf{u}, \bar{\xi}) \geq \mathbf{0}$ will be violated with about 50% probability.

Example: the shortest way with random barrier

R. Henrion, (2006), WIAS, Berlin

Deterministic
barrier

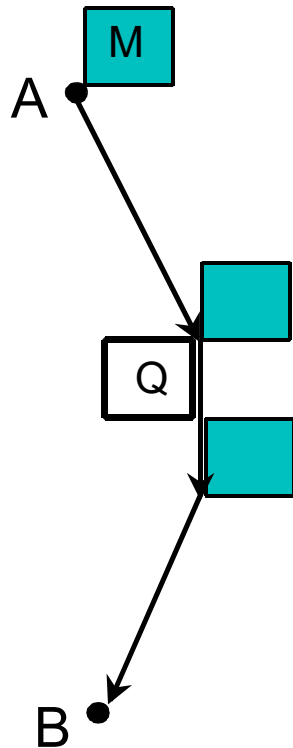

Random barrier (expected
barrier constraint, collision
probability $\approx 50\%$)

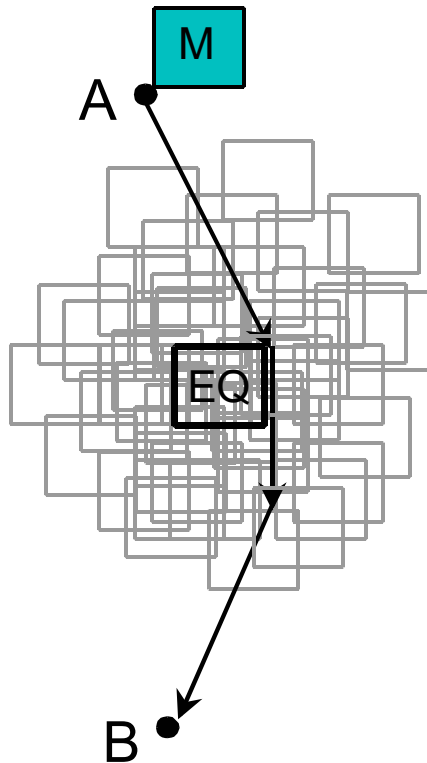

Random barrier (chance
constraint, collision
probability $\approx 10\%$)

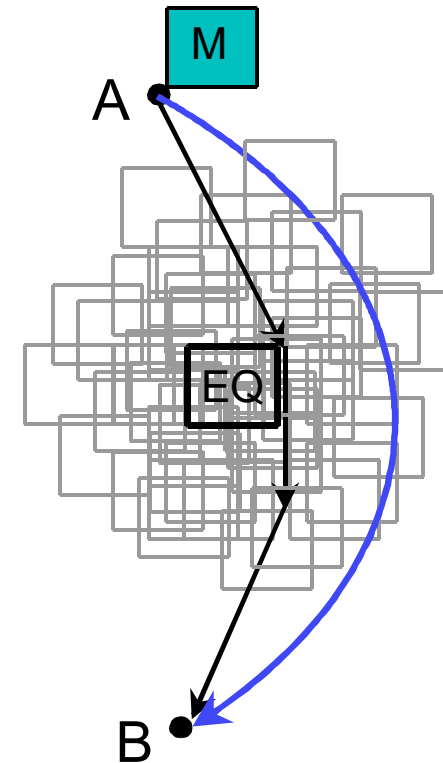

Relaxation of the objective function

$$\min E[f(\mathbf{x}, \mathbf{u}, \xi)] + \omega D[f(\mathbf{x}, \mathbf{u}, \xi)]$$

where

E : expected value

D : variance

ω : weighting factor

If $f(\mathbf{x}, \mathbf{u}, \xi) = f(\mathbf{x}, \mathbf{u})$, relaxation is needed,
because \mathbf{x} is dependent on ξ and thus stochastic.

If $f(\mathbf{x}, \mathbf{u}, \xi) = f(\mathbf{u})$, relaxation is not needed,
because $E[f(\mathbf{u})] = f(\mathbf{u})$ and $D[f(\mathbf{u})] = 0$.

Using a step of simulation:

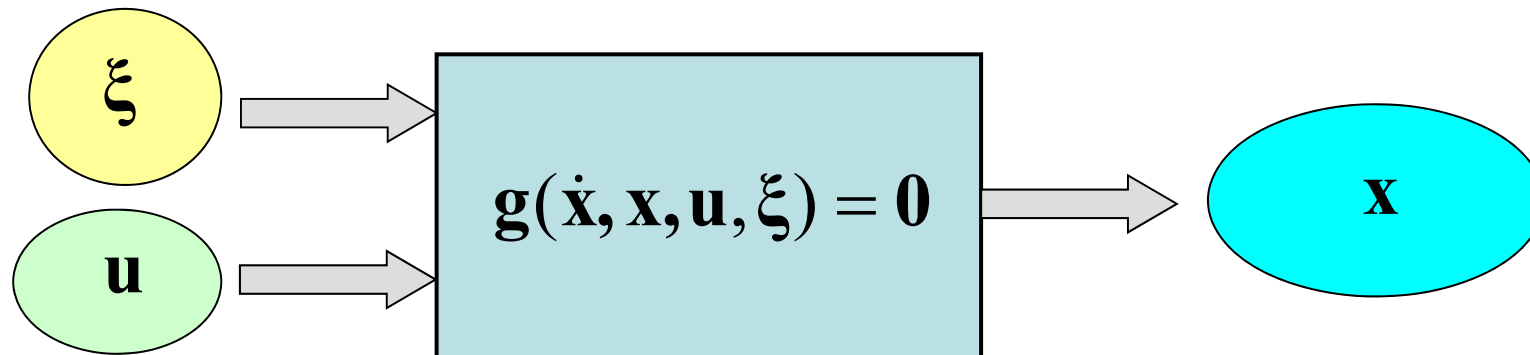

- Model equations should be held for each realization of ξ .
- With given ξ and \mathbf{u} model equations can be solved to obtain \mathbf{x} .
- It only makes sense to simulate with stochastic inputs ξ .
- Model equations are eliminated in the problem formulation.

- **Compensation (recourse):**

$$\begin{aligned} \min \quad & f(\mathbf{x}, \mathbf{u}) + \mathbb{E}[s(\mathbf{x}, \mathbf{u}, \boldsymbol{\theta})] \\ \text{s.t.} \quad & \mathbf{h}(\dot{\mathbf{x}}, \mathbf{x}, \mathbf{u}, \boldsymbol{\xi}) \geq \mathbf{0} \end{aligned}$$

In process optimization problems, it is difficult to define a suitable compensation function.

- **Probabilistic (chance) constraints:**

$$\mathbb{P}\{\mathbf{h}(\dot{\mathbf{x}}, \mathbf{x}, \mathbf{u}, \boldsymbol{\xi}) \geq \mathbf{0}\} \geq \alpha$$

It means holding the inequality constraints with a predefined probability level (reliability of being feasible).

2. Optimization Problems under Uncertainty

- ▶ **Modeling uncertainties**
- ▶ **Generation of uncertain variables**
- ▶ **Simulation of systems with uncertainties**
- ▶ **Formulation of chance constrained optimization problems**

Modeling uncertain variables:

- ▶ Uncertain variables behave differently.
- ▶ Their stochastic properties can be obtained based on analysis of historical data or even experiences of experts.
- ▶ Then they can be formulated according to expected values, standard deviations with probability density functions.

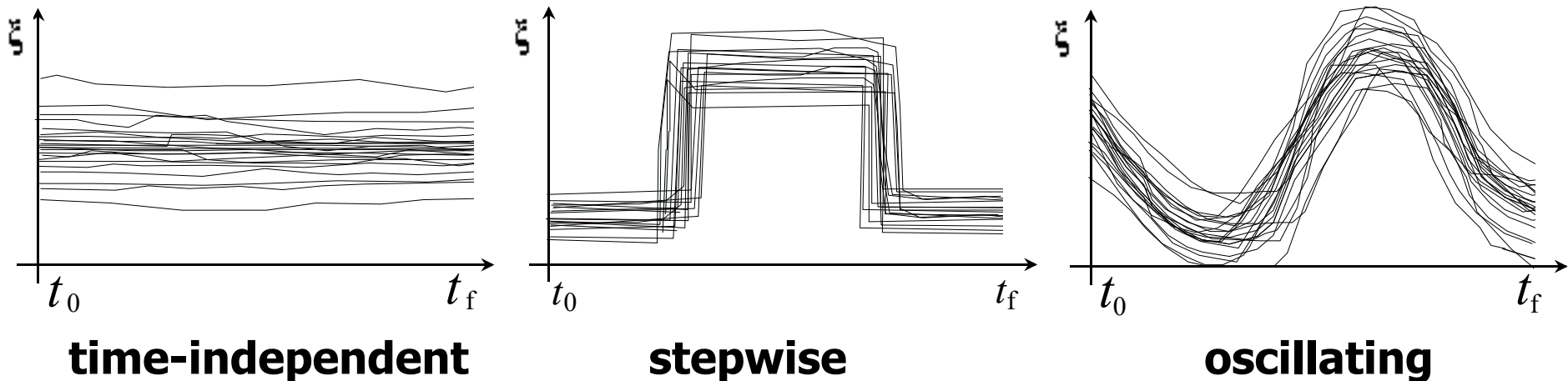

Normal distribution: $\xi \sim N(\mu, \sigma^2)$

The Central Limit Theorem:

A random variable ξ is normally distributed, if it is caused by the summation of many small random variables.

$$\rho(\xi) = \frac{1}{\sqrt{2\pi}\sigma} \exp\left[-\frac{(\xi - \mu)^2}{2\sigma^2}\right], \quad -\infty < \xi < \infty$$

$$P\{|\xi - \mu| < \sigma\} \approx 0,6827$$

$$P\{|\xi - \mu| < 2\sigma\} \approx 0,9545$$

$$F(z) = P\{\xi \leq z\} = \frac{1}{\sqrt{2\pi}\sigma} \int_{-\infty}^z \exp\left[-\frac{(\xi - \mu)^2}{2\sigma^2}\right] d\xi$$

$$P\{|\xi - \mu| < 3\sigma\} \approx 0,9973$$

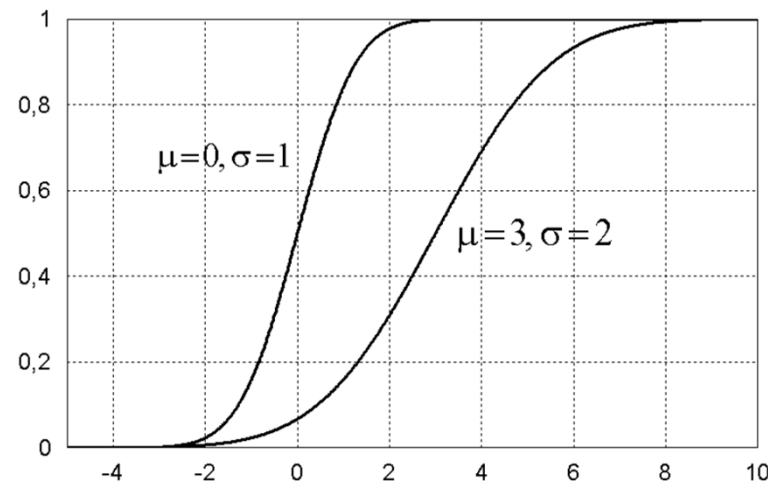
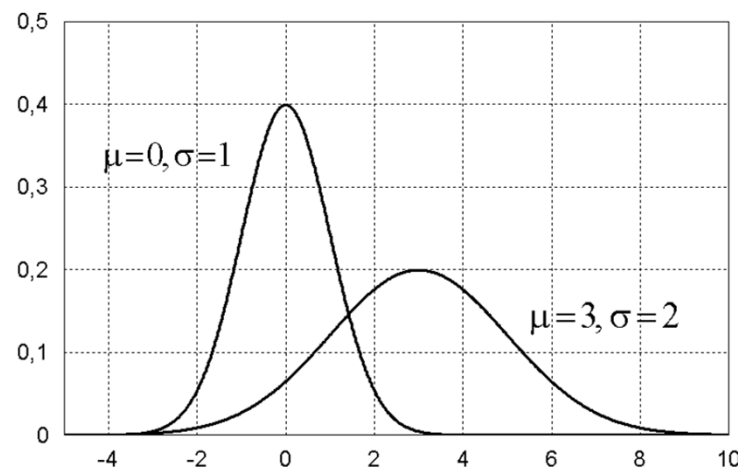

Standardization of normal distribution

$$\xi \sim N(\mu, \sigma^2) \Rightarrow \xi_S \sim N(0, 1)$$

since $F(z) = P\{\xi \leq z\} = \frac{1}{\sqrt{2\pi}\sigma} \int_{-\infty}^z \exp\left[-\frac{(\xi - \mu)^2}{2\sigma^2}\right] d\xi$

$$= \frac{1}{\sqrt{2\pi}} \int_{-\infty}^{\left(\frac{z-\mu}{\sigma}\right)} \exp\left[-\frac{1}{2}\left(\frac{\xi - \mu}{\sigma}\right)^2\right] d\left(\frac{\xi - \mu}{\sigma}\right) = \frac{1}{\sqrt{2\pi}} \int_{-\infty}^{z_S} \exp\left[-\frac{1}{2}\xi_S^2\right] d\xi_S$$

The probability distribution function (PDF):

$$F(z) = P\{\xi \leq z\} = \Phi\left(\frac{z - \mu}{\sigma}\right)$$

The function value can be computed by existing Software.

Multivariate stochastic variables

Consider a vector of random variables: $\xi = [\xi_1 \cdots \xi_m]^T$

Expected values: $\bar{\xi} = [\bar{\xi}_1 \cdots \bar{\xi}_m]^T$

Variances: $\mathbf{D} = [D(\xi_1) \cdots D(\xi_m)]^T$

The covariance matrix:

$$\Sigma = \begin{bmatrix} b_{11} & b_{12} & \cdots & b_{1m} \\ b_{21} & b_{22} & \cdots & b_{2m} \\ \cdots & \cdots & \cdots & \cdots \\ b_{m1} & b_{m2} & \cdots & b_{mm} \end{bmatrix}$$

where $b_{ij} = \text{cov}(\xi_i, \xi_j) = \text{E}[(\xi_i - \bar{\xi}_i)(\xi_j - \bar{\xi}_j)]$

i. e. $b_{ij} = b_{ji}$ (Σ is symmetric)

$b_{ii} = \text{cov}(\xi_i, \xi_i) = \text{E}[(\xi_i - \bar{\xi}_i)^2] = D(\xi_i)$

Correlation coefficient:

$$r_{ij} = \frac{\text{cov}(\xi_i, \xi_j)}{\sqrt{D(\xi_i)D(\xi_j)}} = \frac{E[(\xi_i - \bar{\xi}_i)(\xi_j - \bar{\xi}_j)]}{\sqrt{E[(\xi_i - \bar{\xi}_i)^2]E[(\xi_j - \bar{\xi}_j)^2]}}$$

We have $r_{ii} = 1$ and $-1 < r_{ij} < 1$ for $i \neq j$

- If $r_{ij} = 0$, means $\text{cov}(\xi_i, \xi_j) = 0$, ξ_i, ξ_j have no correlation.
- Without correlation, the covariance matrix is a diagonal matrix.
- If $r_{ij} > 0$, means, if $\xi_i > \bar{\xi}_i$, very probably $\xi_j > \bar{\xi}_j$.

Standard form of the variables: $\xi_{S,i} = \frac{\xi_i - E(\xi_i)}{\sqrt{D(\xi_i)}}, \quad i = 1, \dots, m$

Multivariate normal distribution: $\xi \sim N(\boldsymbol{\mu}, \boldsymbol{\Sigma})$

Probability density function:

$$\rho(\xi_1, \dots, \xi_m) = \frac{1}{\sqrt{(2\pi)^m \det \boldsymbol{\Sigma}}} \exp\left[-\frac{1}{2}(\boldsymbol{\xi} - \boldsymbol{\mu})^T \boldsymbol{\Sigma}^{-1}(\boldsymbol{\xi} - \boldsymbol{\mu})\right]$$

Probability distribution function:

$$\begin{aligned} F(z_1, \dots, z_m) &= P\{\xi_1 \leq z_1, \dots, \xi_m \leq z_m\} = \int_{-\infty}^{z_1} \dots \int_{-\infty}^{z_m} \rho(\xi_1, \dots, \xi_m) d\xi_1 \dots d\xi_m \\ &= \frac{1}{\sqrt{(2\pi)^m \det \boldsymbol{\Sigma}}} \int_{-\infty}^{z_1} \dots \int_{-\infty}^{z_m} \exp\left[-\frac{1}{2}(\boldsymbol{\xi} - \boldsymbol{\mu})^T \boldsymbol{\Sigma}^{-1}(\boldsymbol{\xi} - \boldsymbol{\mu})\right] d\xi_1 \dots d\xi_m \end{aligned}$$

For two random variables ξ_1, ξ_2 :

$$\boldsymbol{\mu} = [\mu_1 \quad \mu_2]^T, \quad \boldsymbol{\Sigma} = \begin{bmatrix} \sigma_1^2 & r_{12}\sigma_1\sigma_2 \\ r_{12}\sigma_1\sigma_2 & \sigma_2^2 \end{bmatrix}$$

Multivariate normal distribution: $\xi \sim N(\mu, \Sigma)$

Linear transformation:

$$\xi \sim N(\mu, \Sigma) \quad \longrightarrow \quad \eta = \mathbf{A}\xi + \mathbf{b} \quad \longrightarrow \quad \eta \sim N(\mathbf{A}\mu + \mathbf{b}, \mathbf{A}\Sigma\mathbf{A}^T)$$

- After a linear transformation the output remains normally distributed.
- Even if ξ has no correlation, η may have correlation.

Stochastic processes:

A time-dependent random variable: $\xi(t), \quad t_0 \leq t \leq t_f$

- At each time point the value of the variable is uncertain.
- There is a mean value profile.
- Between time points usually there exists correlation.

Approximation with piecewise constant random variables, i.e. discretization in m time intervals, such that $\xi(t) = [\xi_1 \cdots \xi_m]^T$

Generation of multivariate normal distribution

- Generation of a vector of uncorrelated standard normally distributed random variables $\xi_S \sim N(\mathbf{0}, \mathbf{I})$.
- Cholesky decomposition of the covariance matrix $\Sigma = \mathbf{L} \mathbf{L}^T$.
- Generation of the desired distribution through linear transformation $\xi = \mathbf{L} \xi_S + \boldsymbol{\mu}$.

For example:
$$\begin{bmatrix} \xi_1 \\ \xi_2 \end{bmatrix} \sim N\left(\begin{bmatrix} \mu_1 \\ \mu_2 \end{bmatrix}, \begin{bmatrix} \sigma_1^2 & r_{12}\sigma_1\sigma_2 \\ r_{12}\sigma_1\sigma_2 & \sigma_2^2 \end{bmatrix}\right) = N\left(\begin{bmatrix} 300 \\ 400 \end{bmatrix}, \begin{bmatrix} 100 & 140 \\ 140 & 400 \end{bmatrix}\right)$$

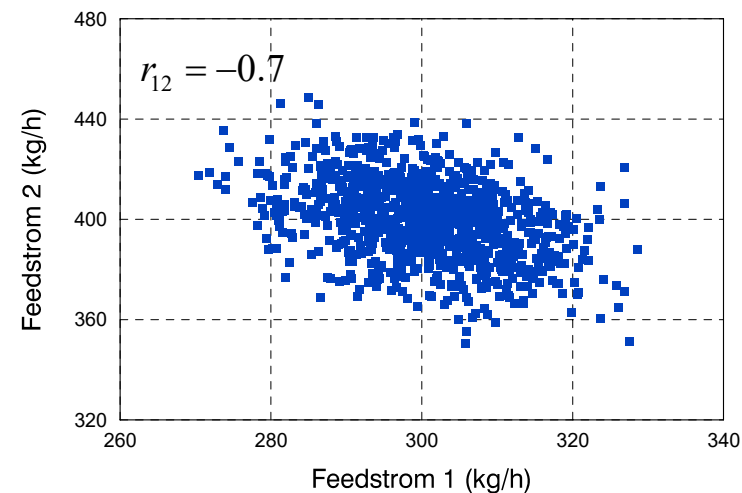
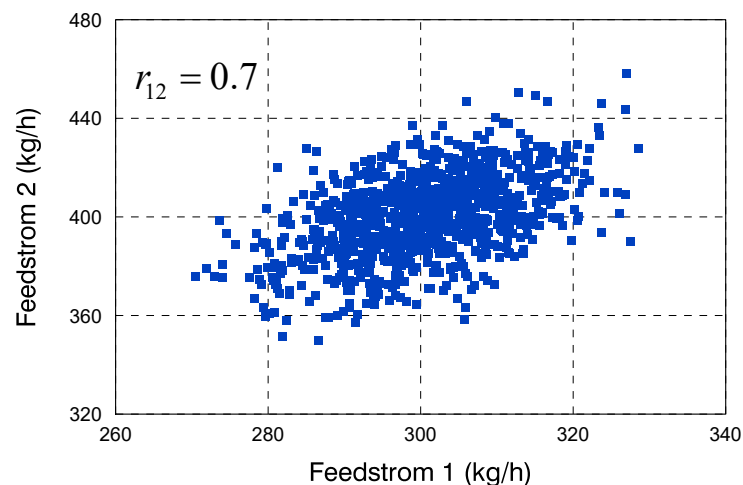

Generation of a stochastic process $\xi(t)$

$\xi(t)$ will be at first discretized piecewise in time intervals.

It is approximated with a constant random variable in each interval.

i.e. $\xi(t) = [\xi_1 \cdots \xi_m]^T$ and $\xi \sim N(\mu, \Sigma)$

For example:

Feed flow rate in 60 days with the following distribution:

$$\mu(k) = 320 - 200(k/60 - 0,5)^2$$

$$\sigma(k) = 20$$

$$r(k, k+i) = 1 - 0,05 i, \quad i = 1, \dots, (60 - k)$$

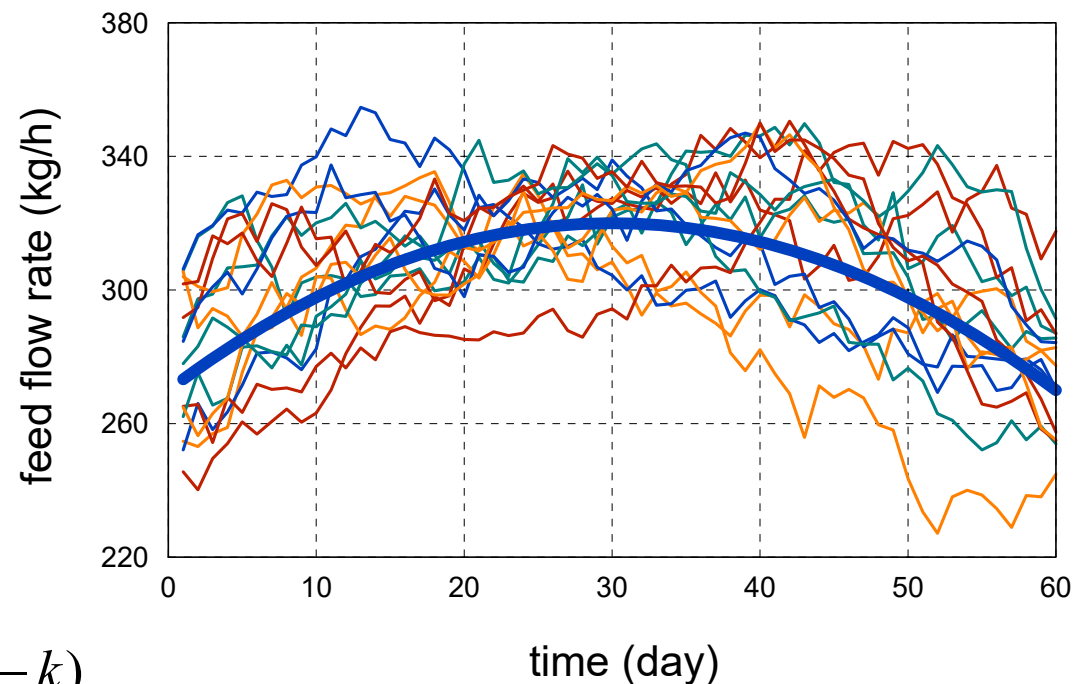

Generation of a stochastic process $\xi(t)$

The impact of correlation and standard deviation:

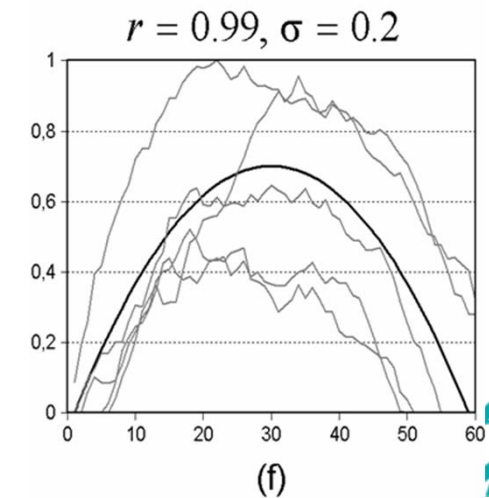
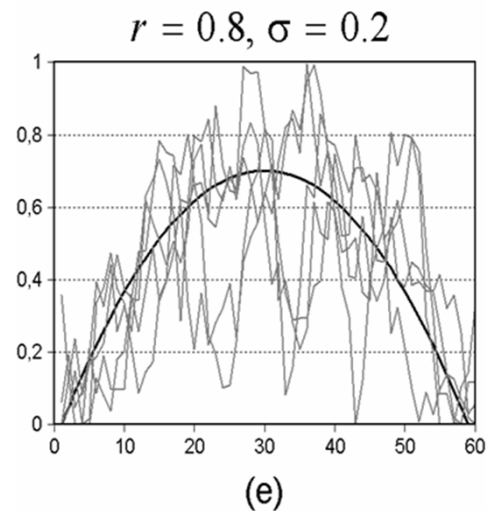
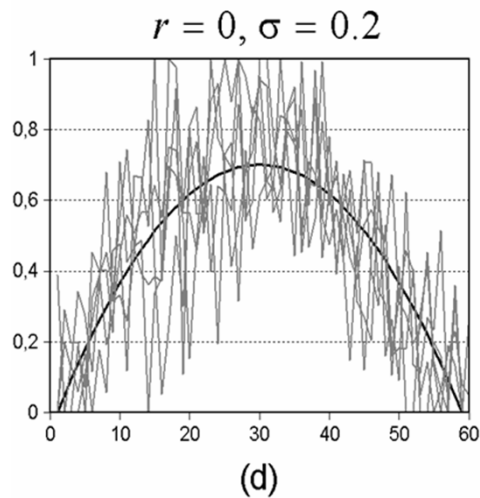
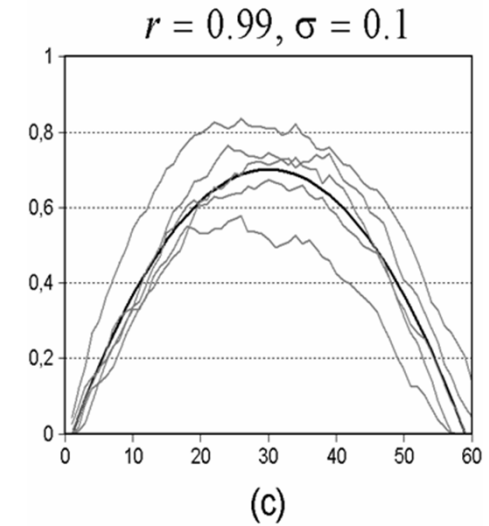
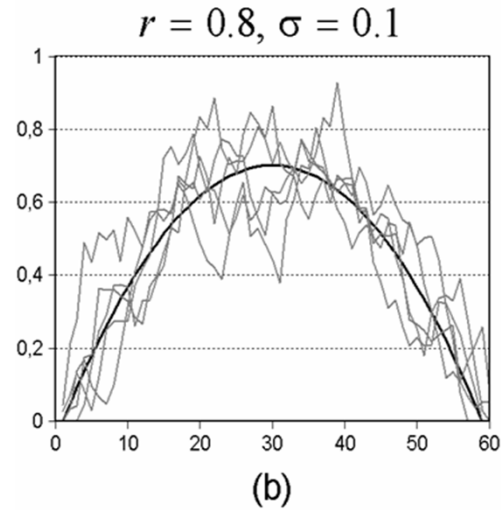
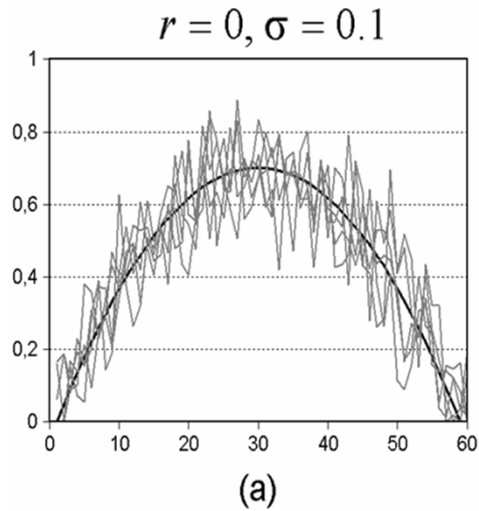

PDF of bivariate normal distribution

$$P\{\xi_1 \leq z_1, \xi_2 \leq z_2\} = F(z_1, z_2) =$$

$$\frac{1}{2\pi\sigma_1\sigma_2\sqrt{(1-r_{12}^2)}} \int_{-\infty}^{z_1} \int_{-\infty}^{z_2} \exp\left[-\frac{1}{2(1-r_{12}^2)} \left(\frac{(\xi_1 - \mu_1)^2}{\sigma_1^2} - 2r_{12} \frac{(\xi_1 - \mu_1)(\xi_2 - \mu_2)}{\sigma_1\sigma_2} + \frac{(\xi_2 - \mu_2)^2}{\sigma_2^2} \right)\right] d\xi_1 d\xi_2$$

If uncorrelated: $r_{12} = 0$

$$F(z_1, z_2) = \frac{1}{\sqrt{2\pi}\sigma_1} \int_{-\infty}^{z_1} \exp\left[-\frac{1}{2} \frac{(\xi_1 - \mu_1)^2}{\sigma_1^2}\right] d\xi_1 \frac{1}{\sqrt{2\pi}\sigma_2} \int_{-\infty}^{z_2} \exp\left[-\frac{1}{2} \frac{(\xi_2 - \mu_2)^2}{\sigma_2^2}\right] d\xi_2 = \Phi\left(\frac{z_1 - \mu_1}{\sigma_1}\right) \Phi\left(\frac{z_2 - \mu_2}{\sigma_2}\right)$$

PDF of bivariate standard normal distribution:

$$\Phi(z_1, z_2, r_{12}) = \int_{-\infty}^{z_1} \int_{-\infty}^{z_2} \rho(\xi_1, \xi_2) d\xi_1 d\xi_2 = \frac{1}{2\pi\sqrt{(1-r_{12}^2)}} \int_{-\infty}^{z_1} \int_{-\infty}^{z_2} \exp\left[-\frac{1}{2(1-r_{12}^2)} (\xi_1^2 - 2r_{12}\xi_1\xi_2 + \xi_2^2)\right] d\xi_1 d\xi_2$$

This function is available in most commercial software. But for $m \geq 3$ one has to do multiple integration or Monte-Carlo simulation.

PDF of bivariate normal distribution

$$P\{\xi_1 \leq z_1, \xi_2 \leq z_2\} = \Phi(z_1, z_2, r_{12})$$

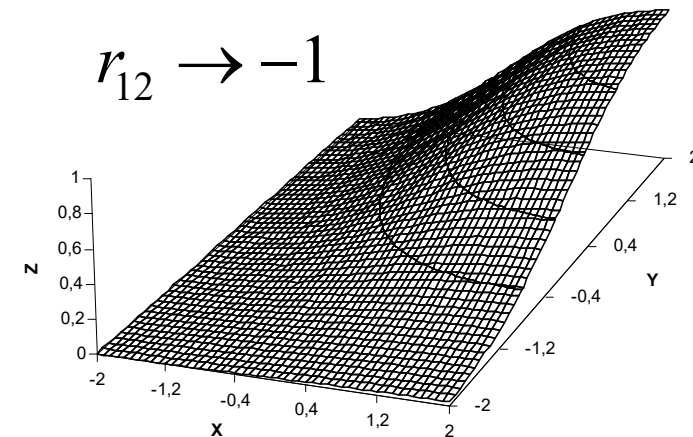
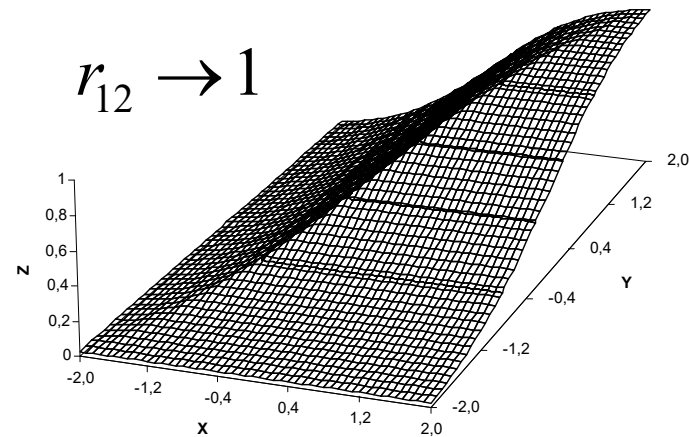
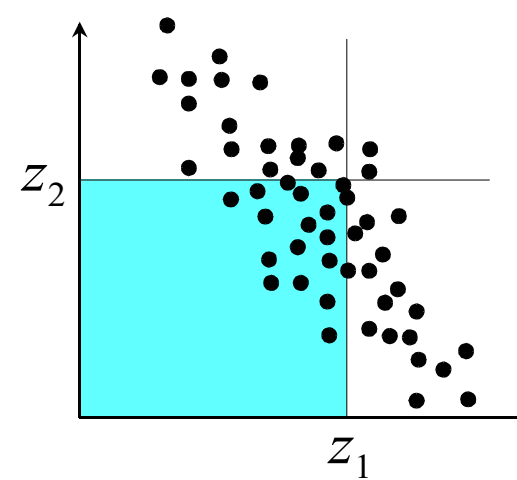
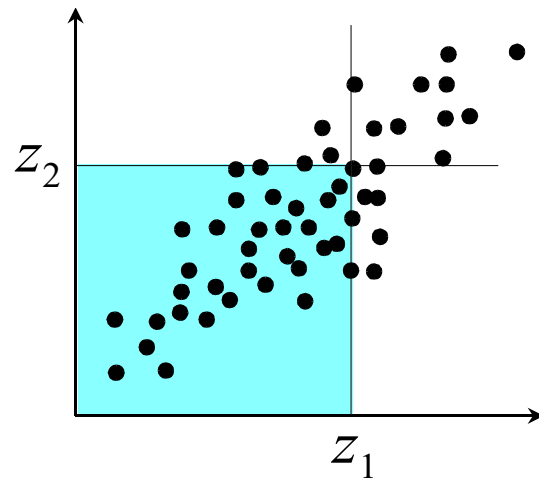

Analysis of influences of uncertain inputs on output variables

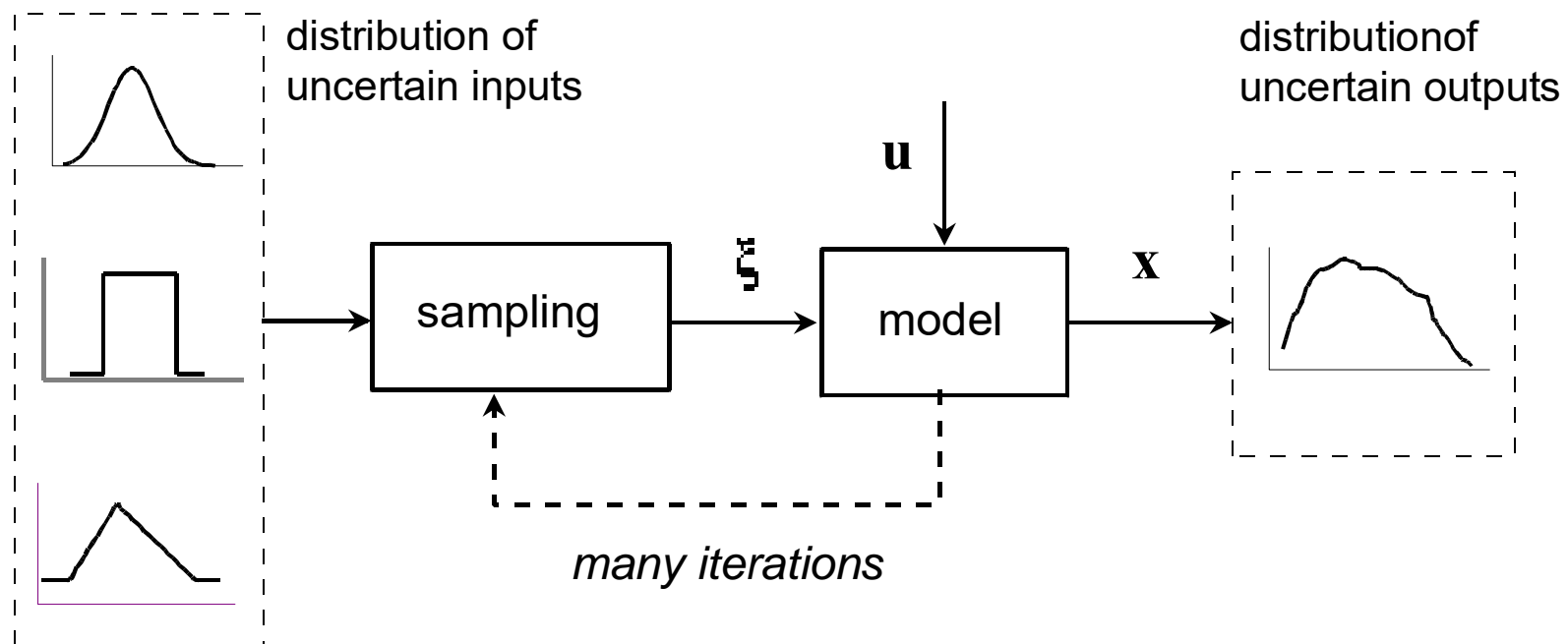

This framework is also called Monte-Carlo simulation.

Due to the nonlinearity it is difficult to directly describe the distribution of the output variables.

Batch distillation: deterministic optimization

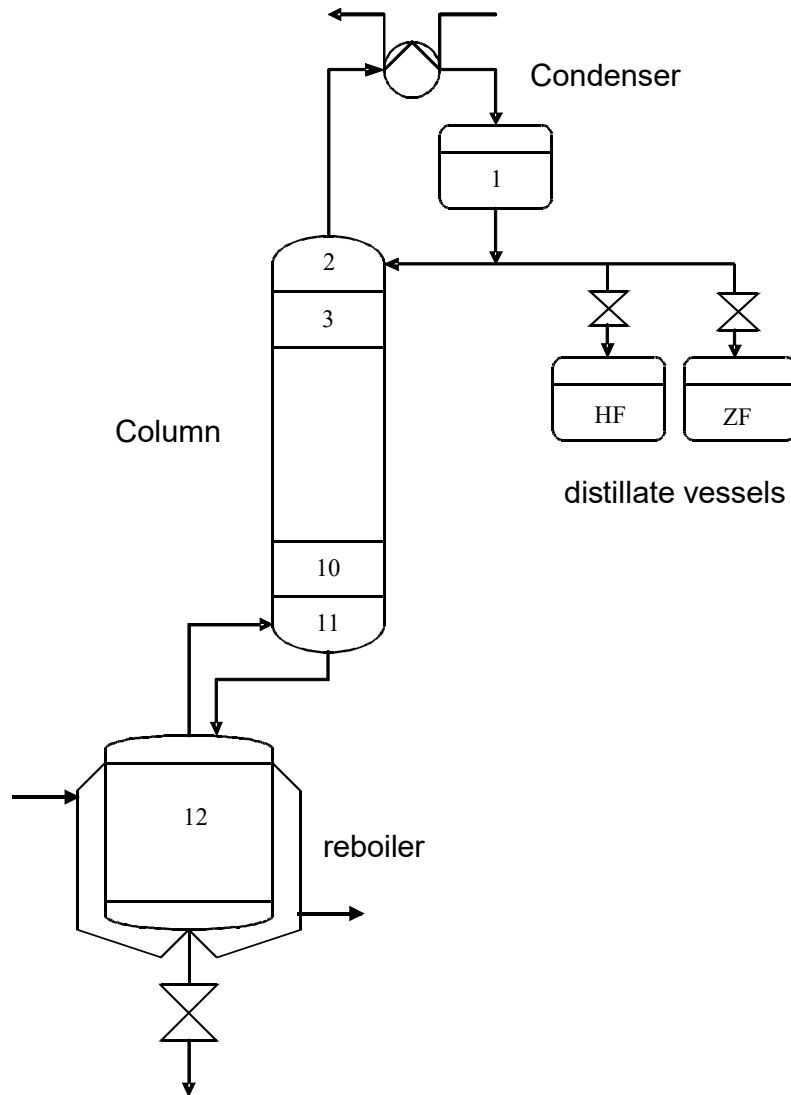

$$\max \text{Profit}(R_V, t_f) = \frac{c_1 H U_{HF}(t_f) + c_2 H U_{12}(t_f)}{t_f} - c_3$$

condenser:
$$\frac{dx_1}{dt} = \frac{V}{H U_1} (y_2 - x_1)$$

trays:
$$\frac{dx_j}{dt} = \frac{V}{H U_j} (y_{j+1} - y_j) + \frac{L}{H U_j} (x_{j-1} - x_j) \quad j = 2, \dots, 11$$

reboiler:
$$\frac{dx_{12}}{dt} = \frac{L}{H U_{12}} (x_{11} - x_{12}) + \frac{V}{H U_{12}} (x_{12} - y_{12})$$

total mass balance:
$$\frac{dH U_{12}}{dt} = -\frac{V}{1 + R_V}$$

phase equilibrium:
$$y_j = \frac{\alpha x_j}{1 + (\alpha - 1)x_j}, \quad j = 2, \dots, 12$$

purity specification:
$$x_{HF}^{SP} \leq \frac{\int_0^{t_f} \frac{x_1 V}{1 + R_V} dt}{\int_0^{t_f} \frac{V}{1 + R_V} dt} \leq 1.0$$

$$x_{12}^{SP} \leq x_{12}(t_f) \leq 1$$

Batch distillation: deterministic optimization

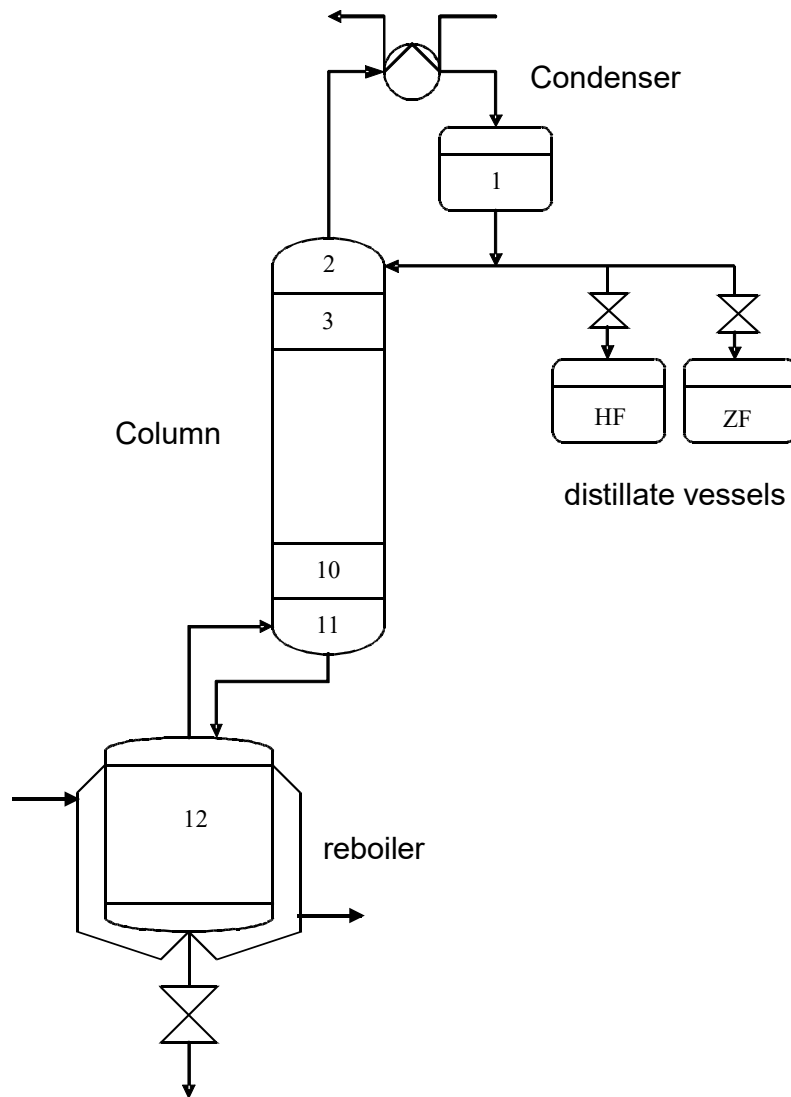

Data predefined in the optimization problem formulation:

condenser:	holdup (HU_1)	5 mol
column:	holdup of the trays (HU_j)	1 mol
reboiler:	start holdup ($HU_{12}(0)$)	100 mol
	start concentration $x_{12}(0)$	0,5 mol/mol
vapor flow (V):		120 mol/h
relative volatility (α):		1,5
product specification:		
distillate vessel 1:	x_{HF}^{SP}	0,95 mol/mol
reboiler:	x_{12}^{SP}	0,05 mol/mol
price factor:		
c_1, c_2, c_3		60, 15, 150

uncertain model parameter: α

uncertain operating condition: $x_{12}(0)$

Batch distillation: deterministic optimization

Results of the deterministic optimization:

uncertain variables set at their expected values

distillate composition

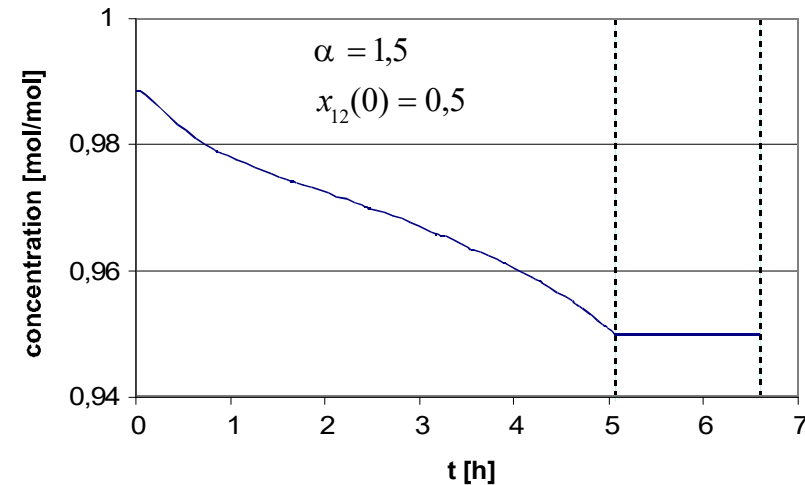

reflux ratio strategy

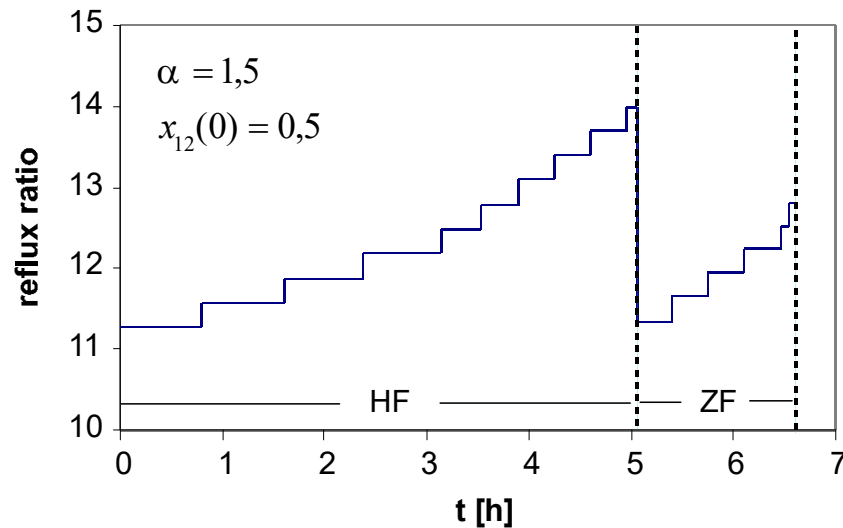

reboiler composition

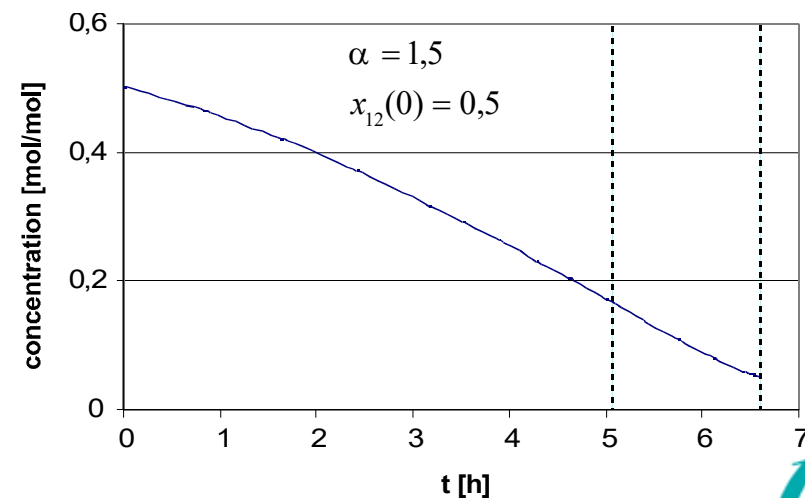

Batch distillation: stochastic simulation

with high uncertainty

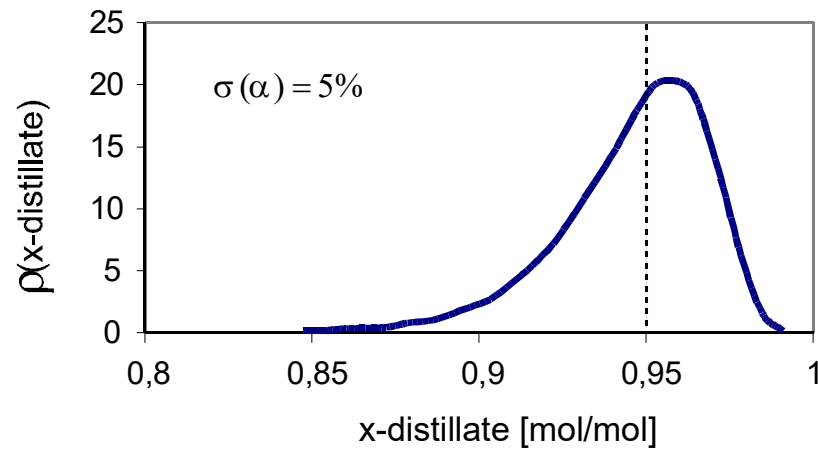

with low uncertainty

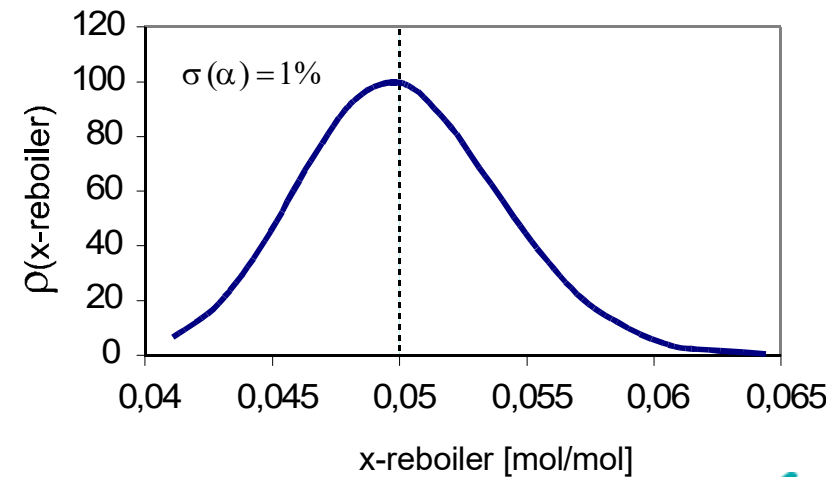
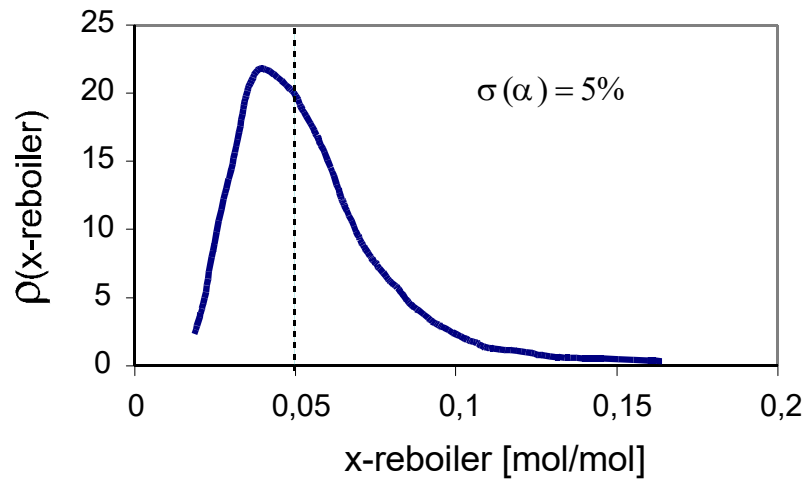
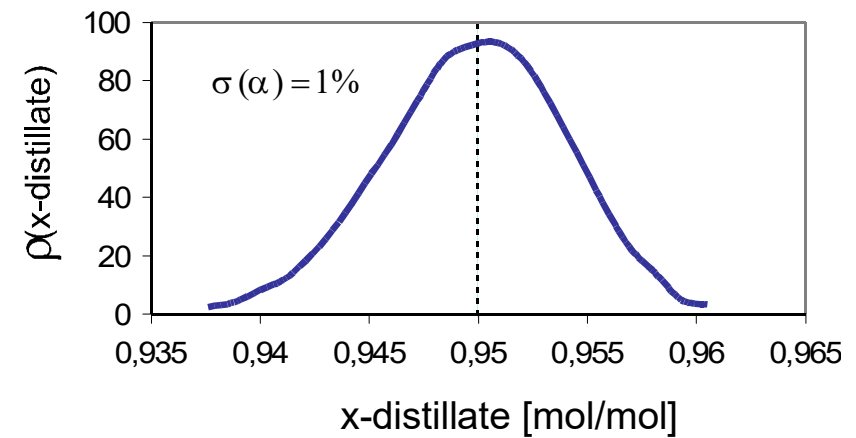

Batch distillation: worst-case operation

The profit increases if relative volatility is higher.

The products will be purer if relative volatility is higher.

The lowest value of relative volatility represents the worst-case operation.

Optimization with the worst-case leads to a conservative operation.

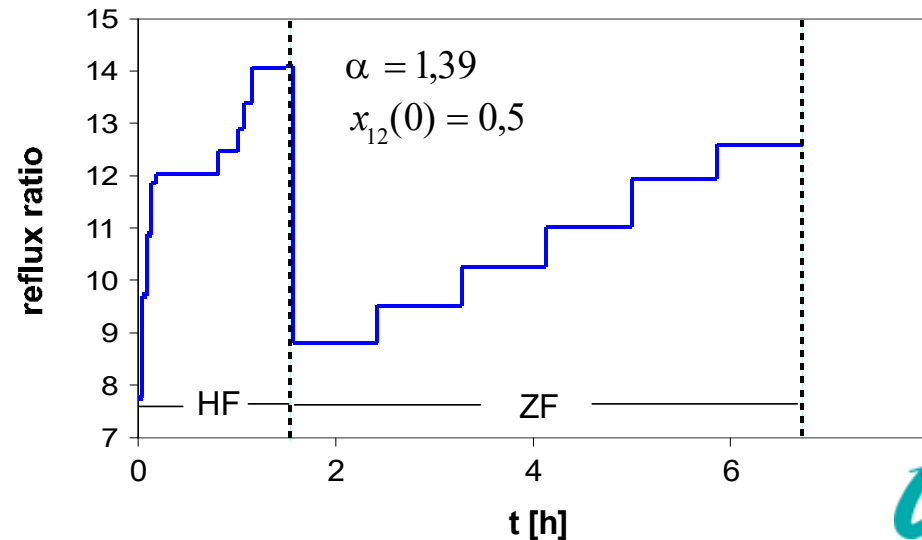
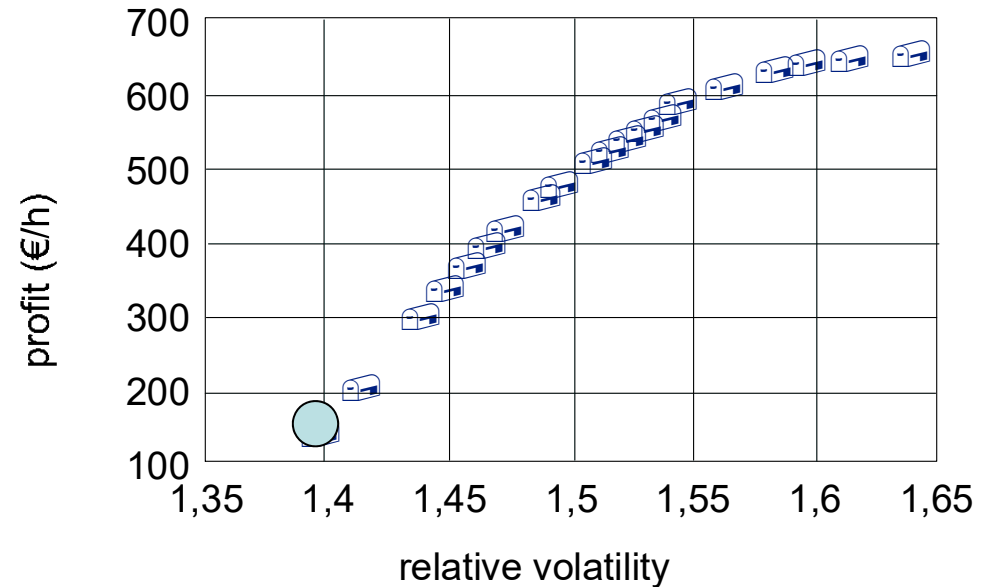

Chance Constrained Optimization

- ▶ The decision should be neither conservative nor aggressive.
- ▶ The restrictions will be satisfied with a desired probability (confidence) level.
- ▶ The expected value of the objective function will be optimized.
- ▶ A robust decision is to be achieved (not depending on the realization of the uncertain variables).

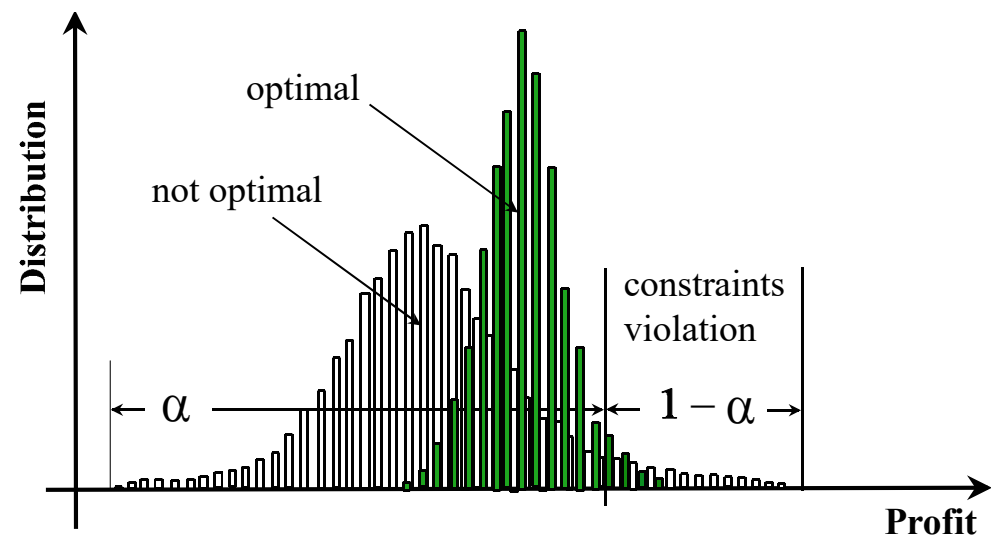
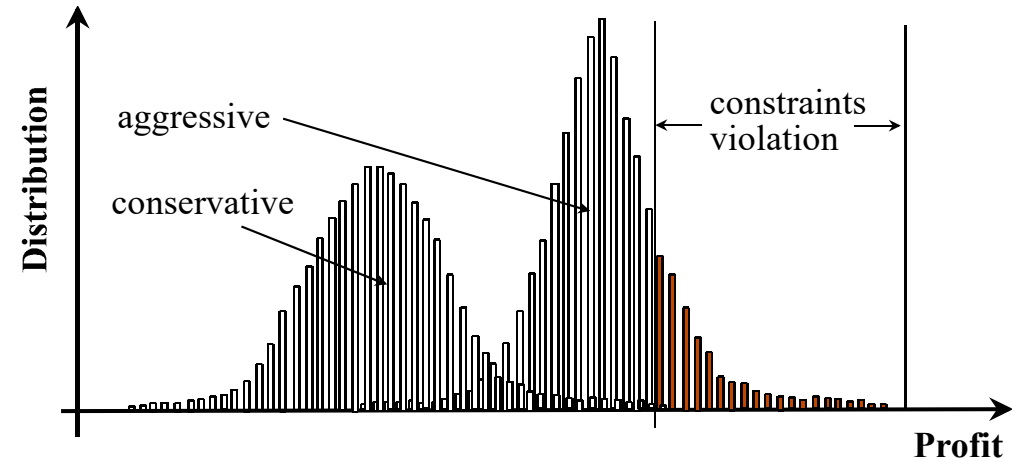

Chance constrained optimization problems

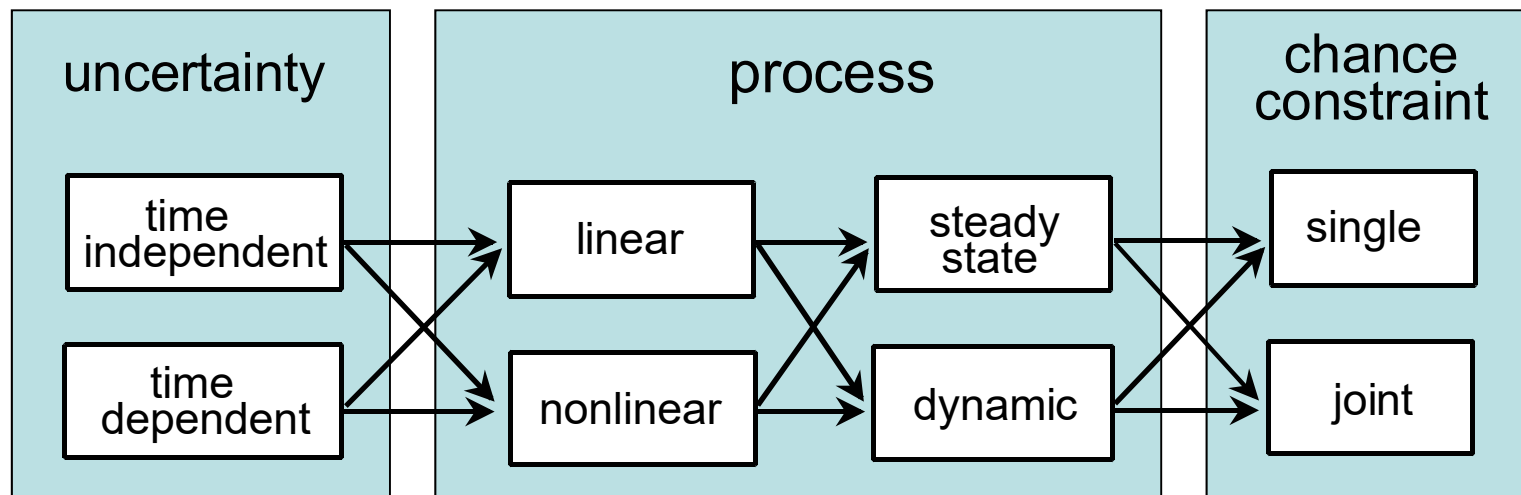
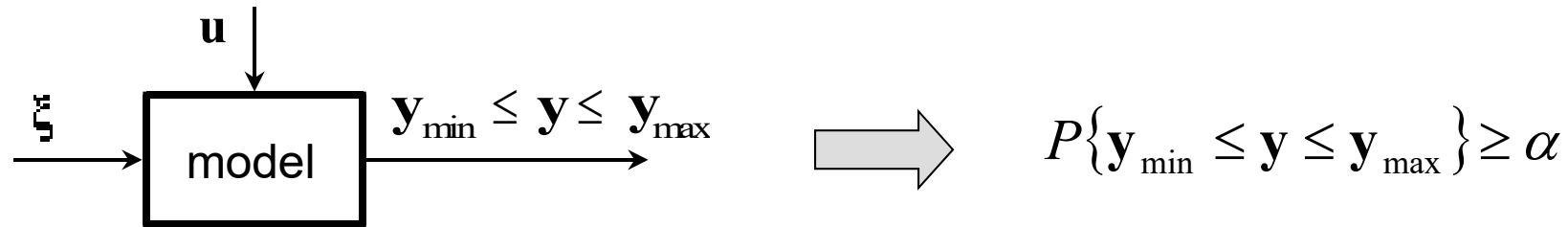

16 types of chance constrained optimization problems

The simplest one: time independent – linear – steady state – single

The most complex: time dependent – nonlinear – dynamic – joint

3. Chance constrained linear optimization

- ▶ **Single and joint chance constraints**
- ▶ **Probability computation for multivariate systems**
- ▶ **Solving the problem with a NLP solver**
- ▶ **Optimal operation of a distillation column with uncertain feed flow rate**

Motivation example: production plan

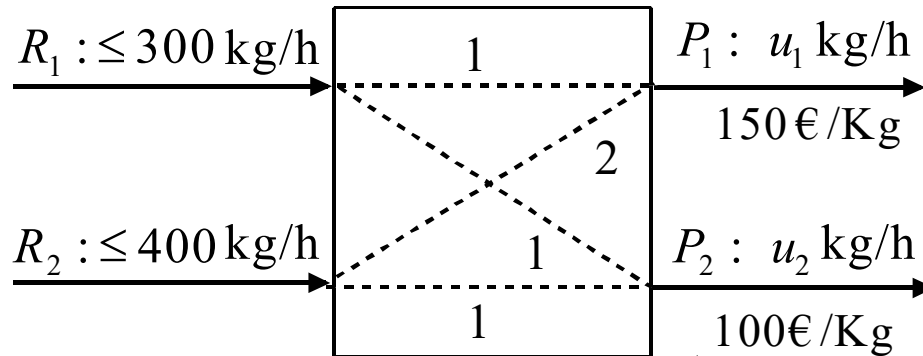

The deterministic problem:

$$\begin{aligned} \max \quad & f(u_1, u_2) = 150u_1 + 100u_2 \\ \text{s.t.} \quad & u_1 + u_2 \leq 300 \\ & 2u_1 + u_2 \leq 400 \\ & u_1 \geq 0, \quad u_2 \geq 0 \end{aligned}$$

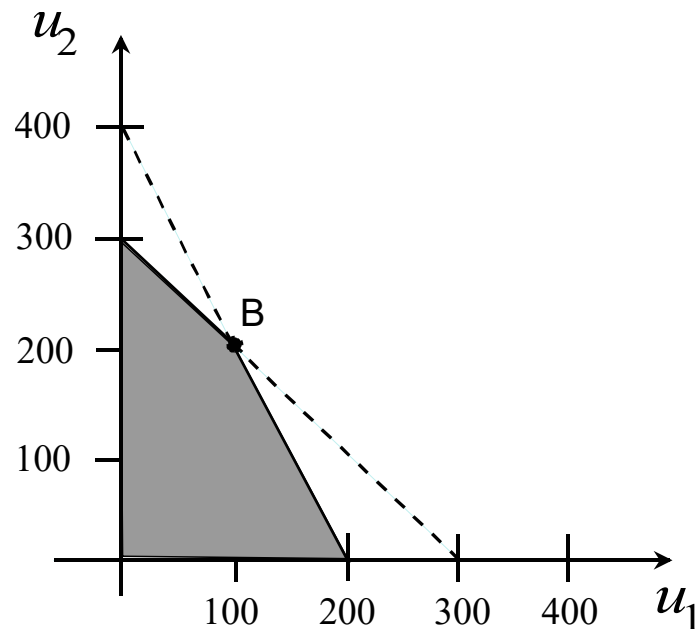

The deterministic solution (point B):

$$\begin{aligned} u_1^* &= 100 \text{ kg/h} \\ u_2^* &= 200 \text{ kg/h} \\ f^* &= 35000 \text{ €/h.} \end{aligned}$$

Solution under uncertain limits of feed streams

$$\begin{aligned} \max \quad & f(u_1, u_2) = 150u_1 + 100u_2 \\ \text{s.t.} \quad & u_1 + u_2 \leq \xi_1 \\ & 2u_1 + u_2 \leq \xi_2 \\ & u_1 \geq 0, \quad u_2 \geq 0 \end{aligned}$$

One can not predict which of the following values will be realized:

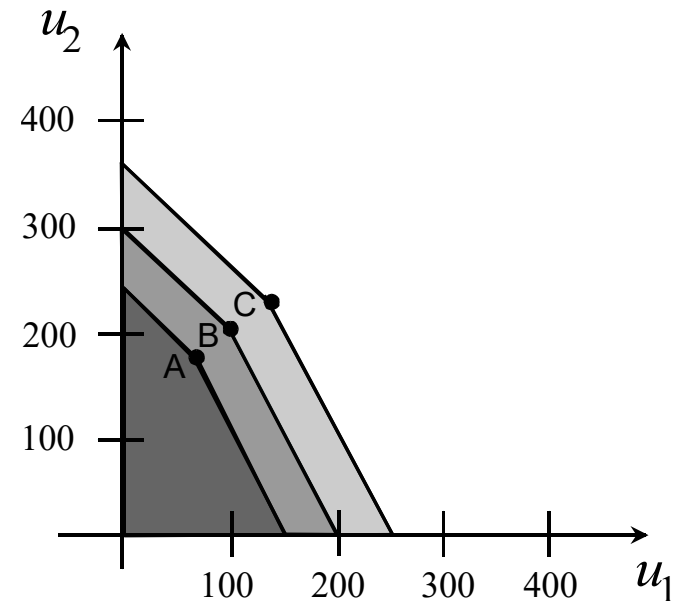

$$\text{A: } \xi_1 = 230, \xi_2 = 300, u_1^* = 70, u_2^* = 160, f^* = 26500$$

$$\text{B: } \xi_1 = 300, \xi_2 = 400, u_1^* = 100, u_2^* = 200, f^* = 35000$$

$$\text{C: } \xi_1 = 360, \xi_2 = 500, u_1^* = 140, u_2^* = 220, f^* = 43000$$

Case 1: single chance constraints

$$\begin{aligned} \max \quad & f(u_1, u_2) = 150u_1 + 100u_2 \\ \text{s.t.} \quad & P\{u_1 + u_2 \leq \xi_1\} \geq 0,9 \\ & P\{2u_1 + u_2 \leq \xi_2\} \geq 0,9 \\ & u_1 \geq 0, \quad u_2 \geq 0 \end{aligned}$$

Case 2: joint chance constraints

$$\begin{aligned} \max \quad & f(u_1, u_2) = 150u_1 + 100u_2 \\ \text{s.t.} \quad & P\left\{ \begin{array}{l} u_1 + u_2 \leq \xi_1 \\ 2u_1 + u_2 \leq \xi_2 \end{array} \right\} \geq 0,9 \\ & u_1 \geq 0, \quad u_2 \geq 0 \end{aligned}$$

Chance (probabilistic) constraints

Case 1: single chance constraints (SCC)

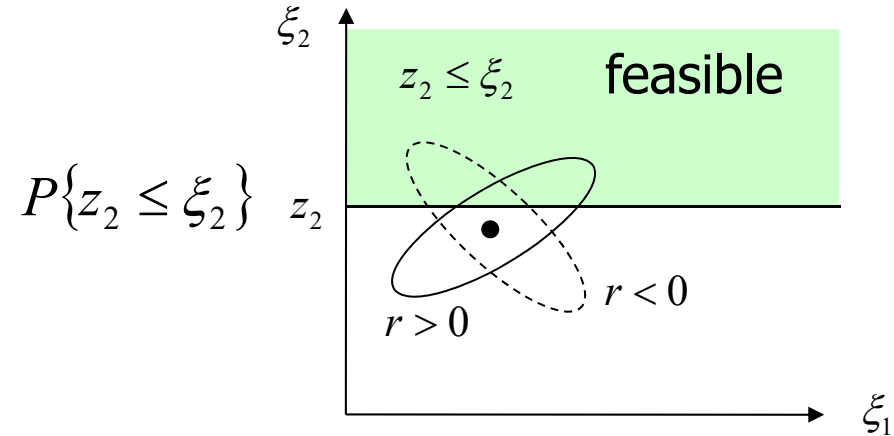
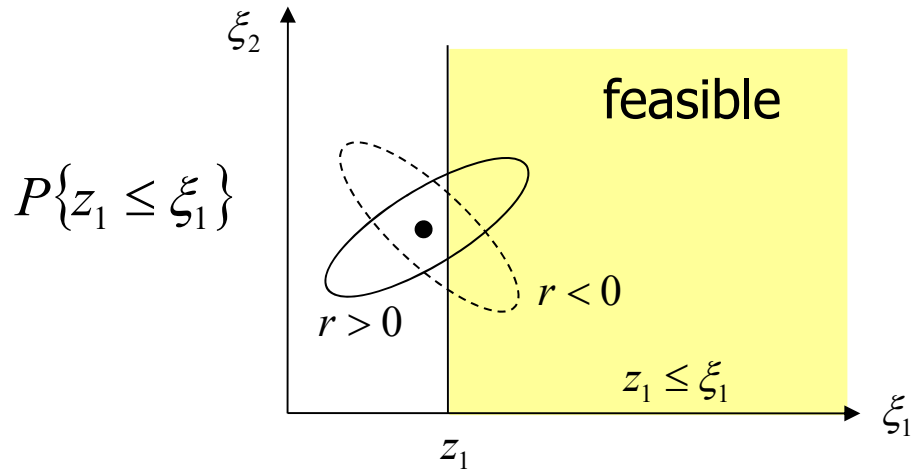

Case 2: joint chance constraints (JCC)

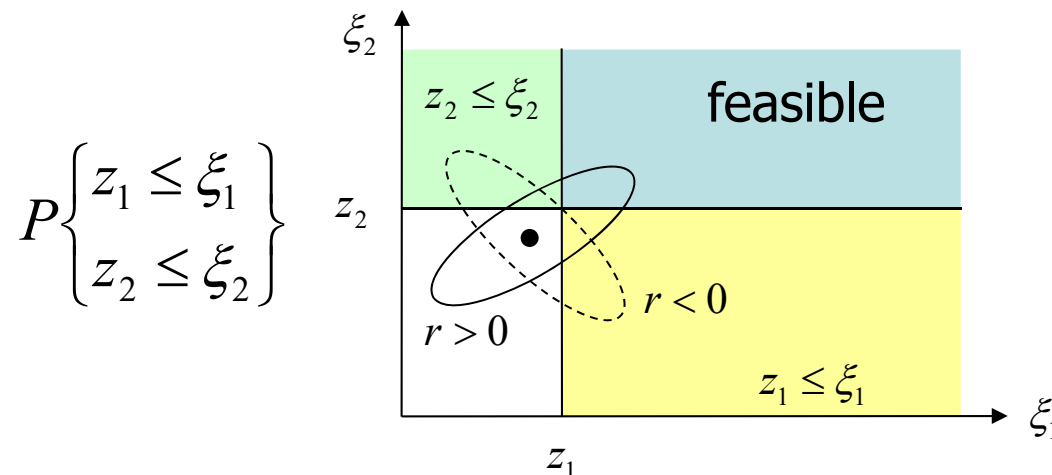

- ▶ JCC is more strict than SCC.
- ▶ The effect of correlation can only be considered by JCC.

Case 1: single chance constraints

$$\begin{aligned} \min \quad & f(\mathbf{u}) = \mathbf{c}^T \mathbf{u} \\ \text{s.t.} \quad & P\{\mathbf{a}_i^T \mathbf{u} + b_i \geq \xi_i\} \geq \alpha_i, \quad i = 1, \dots, m \end{aligned}$$

$$z_i = \mathbf{a}_i^T \mathbf{u} + b_i \geq \xi_i \quad \longrightarrow \quad P\{\xi_i \leq z_i\} \geq \alpha_i, \quad i = 1, \dots, m$$

Standardization:

$$\Phi\left(\frac{z_i - \mu_i}{\sigma_i}\right) \geq \alpha_i$$

Relaxation to deterministic linear constraints:

$$z_i - \mu_i - \sigma_i \Phi^{-1}(\alpha_i) \geq 0, \quad i = 1, \dots, m$$

Note: the correlation can not be dealt with.

For the example:

$$\max f(u_1, u_2) = 150u_1 + 100u_2$$

$$\text{s.t. } P\{u_1 + u_2 \leq \xi_1\} \geq 0,9$$

$$P\{2u_1 + u_2 \leq \xi_2\} \geq 0,9$$

$$\begin{bmatrix} \xi_1 \\ \xi_2 \end{bmatrix} \sim N\left(\begin{bmatrix} \mu_1 \\ \mu_2 \end{bmatrix}, \begin{bmatrix} \sigma_1^2 & r_{12}\sigma_1\sigma_2 \\ r_{12}\sigma_1\sigma_2 & \sigma_2^2 \end{bmatrix}\right) = N\left(\begin{bmatrix} 300 \\ 400 \end{bmatrix}, \begin{bmatrix} 100 & 200r_{12} \\ 200r_{12} & 400 \end{bmatrix}\right)$$

The relaxed problem:

$$\max f(u_1, u_2) = 150u_1 + 100u_2$$

$$\text{s.t. } u_1 + u_2 \leq 300 - 10 \Phi^{-1}(0,9)$$

$$2u_1 + u_2 \leq 400 - 20 \Phi^{-1}(0,9)$$

$$u_1 \geq 0, \quad u_2 \geq 0$$

The solution of the SCC problem: $u_1^* = 87,2, u_2^* = 200, f^* = 33080$

The solution with the expected values: $u_1^* = 100, u_2^* = 200, f^* = 35000$

Case 2: joint chance constraints

$$\begin{aligned} \min \quad & f(\mathbf{u}) = \mathbf{c}^T \mathbf{u} \\ \text{s.t.} \quad & P\left\{\mathbf{a}_i^T \mathbf{u} + b_i \geq \xi_i, \quad i = 1, \dots, m\right\} \geq \alpha \end{aligned}$$

Standardization:
$$z_i = \frac{\mathbf{a}_i^T \mathbf{u} + b_i - \mu_i}{\sigma_i} \geq \frac{\xi_i - \mu_i}{\sigma_i} = \xi_{S,i}, \quad i = 1, \dots, m$$

Relaxation to one deterministic constraint:

$$\Phi(z_1, \dots, z_m) = P\left\{\xi_{S,i} \leq z_i, \quad i = 1, \dots, m\right\} \geq \alpha$$

- A numerical integration is required.
- The constraint is nonlinear, i.e. a NLP solver has to be used.
- Using NLP gradients have to be computed.
- The effect of correlation is considered.

Linear chance constrained programming

For the example:

$$\max f(u_1, u_2) = 150u_1 + 100u_2$$

$$\text{s.t. } P \left\{ \begin{array}{l} u_1 + u_2 \leq \xi_1 \\ 2u_1 + u_2 \leq \xi_2 \end{array} \right\} \geq 0,9$$

$$\begin{bmatrix} \xi_1 \\ \xi_2 \end{bmatrix} \sim N \left(\begin{bmatrix} \mu_1 \\ \mu_2 \end{bmatrix}, \begin{bmatrix} \sigma_1^2 & r_{12}\sigma_1\sigma_2 \\ r_{12}\sigma_1\sigma_2 & \sigma_2^2 \end{bmatrix} \right) = N \left(\begin{bmatrix} 300 \\ 400 \end{bmatrix}, \begin{bmatrix} 100 & 200r_{12} \\ 200r_{12} & 400 \end{bmatrix} \right)$$

Define $z_1 = u_1 + u_2$, $z_2 = 2u_1 + u_2$ then

$$\begin{aligned} P \left\{ \begin{array}{l} u_1 + u_2 \leq \xi_1 \\ 2u_1 + u_2 \leq \xi_2 \end{array} \right\} &= P \left\{ \begin{array}{l} z_1 \leq \xi_1 \\ z_2 \leq \xi_2 \end{array} \right\} = 1 - P\{\xi_1 \leq z_1\} - P\{\xi_2 \leq z_2\} + P \left\{ \begin{array}{l} \xi_1 \leq z_1 \\ \xi_2 \leq z_2 \end{array} \right\} \\ &= 1 - \Phi(z_1) - \Phi(z_2) + \Phi(z_1, z_2, r_{12}) \end{aligned}$$

Probability function:
$$\Phi(z_1, z_2, r_{12}) = \int_{-\infty}^{z_1} \int_{-\infty}^{z_2} \rho(\xi_1, \xi_2) d\xi_1 d\xi_2 = P\{\xi_1 \leq z_1, \xi_2 \leq z_2\}$$

$$= \frac{1}{2\pi\sqrt{(1-r_{12}^2)}} \int_{-\infty}^{z_1} \int_{-\infty}^{z_2} \exp \left[-\frac{1}{2(1-r_{12}^2)} (\xi_1^2 - 2r_{12}\xi_1\xi_2 + \xi_2^2) \right] d\xi_1 d\xi_2$$

The derivatives:
$$\frac{\partial \Phi(z_1, z_2, r_{12})}{\partial z_1} = \Phi \left(\frac{z_2 - r_{12} \cdot z_1}{\sqrt{1 - r_{12}^2}} \right) \cdot \rho(z_1)$$

The gradients:
$$\frac{\partial P}{\partial u_i} = \frac{\partial P(z_1, z_2, r_{12})}{\partial z_1} \frac{\partial z_1}{\partial u_i} + \frac{\partial P(z_1, z_2, r_{12})}{\partial z_2} \frac{\partial z_2}{\partial u_i}, \quad i = 1, 2$$

The impact of correlation on the solution:

r_{12}	u_1^*	u_2^*	f^*
-0.99	89.4	191.7	32584
-0.7	89.4	191.7	32584
0.0	89.2	192.2	32600
0.7	88.5	194.7	32739
0.9	88.0	196.6	32861
0.99	87.4	198.8	33003

A higher correlation leads to a higher profit.

$$\Phi(z_1, \dots, z_m) = P\{\xi_i \leq z_i, \quad i = 1, \dots, m\} = ?$$

We define m events: A_1, A_2, \dots, A_m with $A_i : \xi_i \leq z_i, i = 1, \dots, m$

$$P(A) = P(A_1 \cap A_2 \cap \dots \cap A_m) = 1 - P(\bar{A}_1 \cup \bar{A}_2 \cup \dots \cup \bar{A}_m)$$

Using the inclusive-exclusive-formula:

$$\begin{aligned} P(\bar{A}_1 \cup \bar{A}_2 \cup \dots \cup \bar{A}_m) &= \sum_{1 \leq i \leq m} P(\bar{A}_i) - \sum_{1 \leq i, j \leq m, i \neq j} P(\bar{A}_i \cap \bar{A}_j) + \sum_{1 \leq i, j, k \leq m, i \neq j \neq k} P(\bar{A}_i \cap \bar{A}_j \cap \bar{A}_k) \\ &\quad - \dots + (-1)^{m-1} P(\bar{A}_1 \cap \bar{A}_2 \cap \dots \cap \bar{A}_m) \\ &= \bar{S}_1 - \bar{S}_2 + \bar{S}_3 - \dots + (-1)^{m-1} \bar{S}_m \end{aligned}$$

then
$$P(A) = 1 - \bar{S}_1 + \bar{S}_2 - \bar{S}_3 + \dots + (-1)^m \bar{S}_m$$

Approximation of \bar{S}_k based on sampling:

- Monte-Carlo sampling with total number of samples N .
- Counting the number of violations of $\xi_i \leq z_i$ ($i = 1, \dots, m$) for each sample k_s .

$$\bar{S}_k \approx \frac{1}{N} \sum_{s=1}^N \binom{k_s}{k}, \quad k = 1, \dots, m$$

Three approximated values of $P(A)$:

$$\hat{P}_0(A) = \nu_0, \quad \hat{P}_1(A) = 1 - \bar{S}_1 + \nu_1, \quad \hat{P}_2(A) = 1 - \bar{S}_1 + \bar{S}_2 + \nu_2$$

with

$$\nu_0 = \frac{1}{N} \sum_{s=1}^N k'_s, \quad \text{and} \quad k'_s = \begin{cases} 1 & \text{if } k_s = 0 \\ 0 & \text{if } k_s \neq 0 \end{cases}$$

$$\nu_1 = \frac{1}{N} \sum_{s=1}^N \max(k_s - 1, 0)$$

$$\nu_2 = \frac{-1}{N} \sum_{s=1}^N k''_s \quad \text{and} \quad k''_s = \begin{cases} \binom{k_s - 1}{2} & \text{if } k_s \geq 2 \\ 0 & \text{if } k_s < 2 \end{cases}$$

For example:

$$P\{\xi_i \leq z_i, i = 1, \dots, 4\} = P(A_1 \cap A_2 \cap A_3 \cap A_4) = 1 - P(\bar{A}_1 \cup \bar{A}_2 \cup \bar{A}_3 \cup \bar{A}_4)$$

$$\begin{aligned} P(\bar{A}_1 \cup \bar{A}_2 \cup \bar{A}_3 \cup \bar{A}_4) &= [P(\bar{A}_1) + P(\bar{A}_2) + P(\bar{A}_3) + P(\bar{A}_4)] \\ &\quad - [P(\bar{A}_1 \cap \bar{A}_2) + P(\bar{A}_1 \cap \bar{A}_3) + P(\bar{A}_1 \cap \bar{A}_4) + P(\bar{A}_2 \cap \bar{A}_3) + P(\bar{A}_2 \cap \bar{A}_4) + P(\bar{A}_3 \cap \bar{A}_4)] \\ &\quad + [P(\bar{A}_1 \cap \bar{A}_2 \cap \bar{A}_3) + P(\bar{A}_1 \cap \bar{A}_2 \cap \bar{A}_4) + P(\bar{A}_1 \cap \bar{A}_3 \cap \bar{A}_4) + P(\bar{A}_2 \cap \bar{A}_3 \cap \bar{A}_4)] \\ &\quad - P(\bar{A}_1 \cap \bar{A}_2 \cap \bar{A}_3 \cap \bar{A}_4) = \bar{S}_1 - \bar{S}_2 + \bar{S}_3 - \bar{S}_4 \end{aligned}$$

A sample $\xi^{(s)} = (\xi_1^{(s)}, \xi_2^{(s)}, \xi_3^{(s)}, \xi_4^{(s)})^T$ leads to $\bar{S}_k^{(s)} = \begin{pmatrix} k_s \\ k \end{pmatrix}$

No. of violations	k_s	0	1	2	3	4
$\bar{S}_2^{(s)}$		0	0	1	3	6
$\bar{S}_3^{(s)}$		0	0	0	1	4
$\bar{S}_4^{(s)}$		0	0	0	0	1

Approximated value of $P(A)$:

$$\hat{P}(A) = \omega_0 \hat{P}_0(A) + \omega_1 \hat{P}_1(A) + \omega_2 \hat{P}_2(A)$$

The weighting factors $\boldsymbol{\omega} = (\omega_0, \omega_1, \omega_2)^T$ can be gained by solving the quadratic optimization problem:

$$\begin{aligned} \min \quad & \boldsymbol{\omega}^T \boldsymbol{\Sigma}_P \boldsymbol{\omega} \\ \text{s.t.} \quad & \omega_0 + \omega_1 + \omega_2 = 1 \\ & \omega_0, \omega_1, \omega_2 \geq 0 \end{aligned}$$

where $\boldsymbol{\Sigma}_P$ is the covariance matrix of $\hat{P}_0(A), \hat{P}_1(A), \hat{P}_2(A)$ which can be computed based on the results of sampling.

Hammersley Sequence Sampling (HSS):

Using a quasi-random generator (HSS) to enhance the sampling efficiency up to a factor of 100.

To generate N samples a vector of random numbers: $\zeta = [\zeta_1 \cdots \zeta_m]^T$, $\zeta_i \in [0, 1]$

we need $m - 1$ primal numbers: R_i , $i = 1, \dots, m - 1$

1) Integer number: $n = n_l n_{l-1} \dots n_2 n_1 n_0 = n_0 + n_1 R_i + n_2 R_i^2 + \dots + n_l R_i^l$

where $l = \text{mod}(\log_{R_i} n) = \text{mod}[(\ln n) / (\ln R_i)]$

2) Decimal number:

$$\phi_R(n) = 0, n_0 n_1 n_2 \dots n_l = n_0 R_i^{-1} + n_1 R_i^{-2} + \dots + n_l R_i^{-l-1}$$

3) A vector of decimal numbers:

$$\mathbf{z}(n) = \left(\frac{n}{N}, \phi_{R_1}(n), \phi_{R_2}(n), \dots, \phi_{R_{m-1}}(n) \right)$$

4) Random vector desired:

$$\zeta(n) = 1 - \mathbf{z}(n), \quad n = 1, 2, \dots, N$$

Computing joint probability of multivariate systems

random sampling

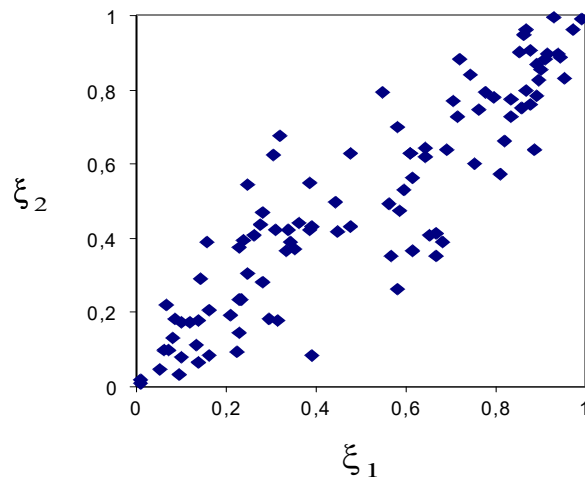

HSS sampling

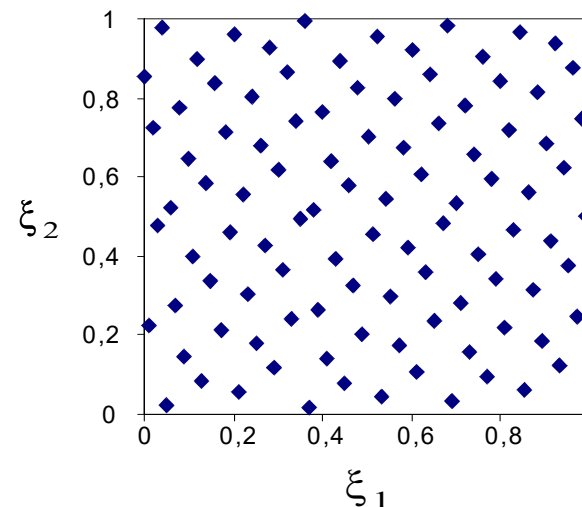
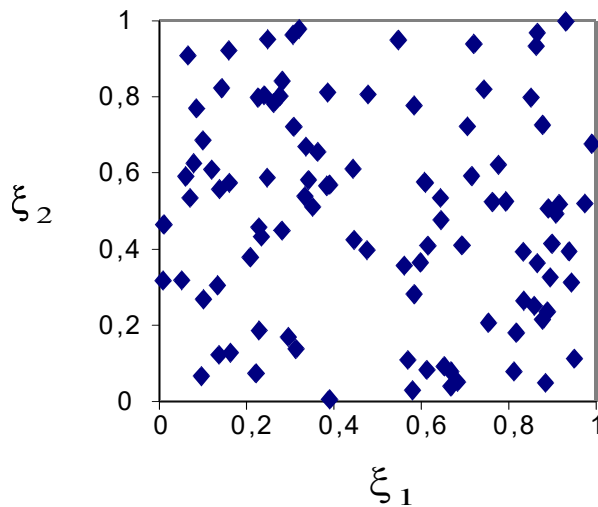
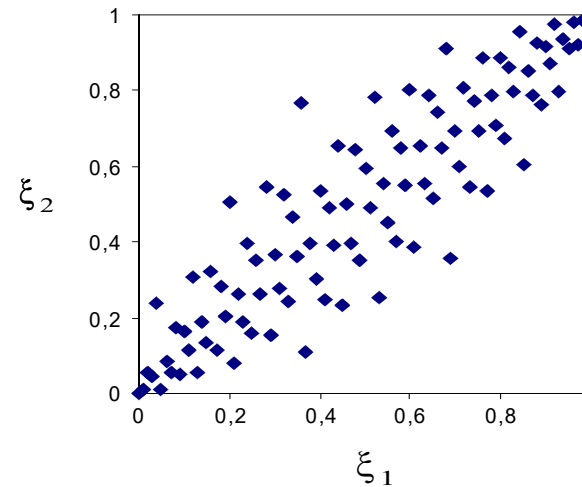

Distillation operation under uncertain feed flow

Li et al., AIChE Journal, 2002, 1198-1211.

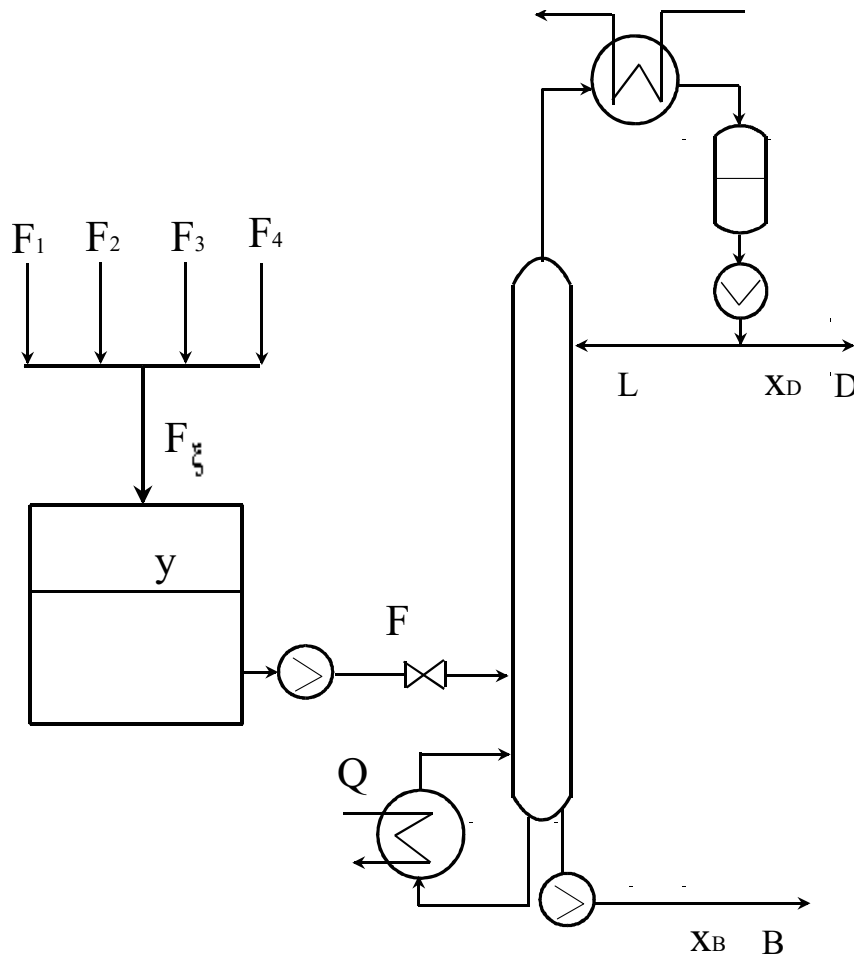

A common problem:

- Feed flow comes from upstream plants.
- They have different stochastic distributions.
- Total flow is small in the night and at weekends.
- It is large on normal working days.

Consequences:

- Tank level higher than upper bounds: special vessels are needed.
- Tank level lower than lower bound: the column has to be operated with recycle.
- The column operation is often significantly disturbed.

Distillation operation under uncertain feed flow

Measured feed profiles of an industrial methanol-water column

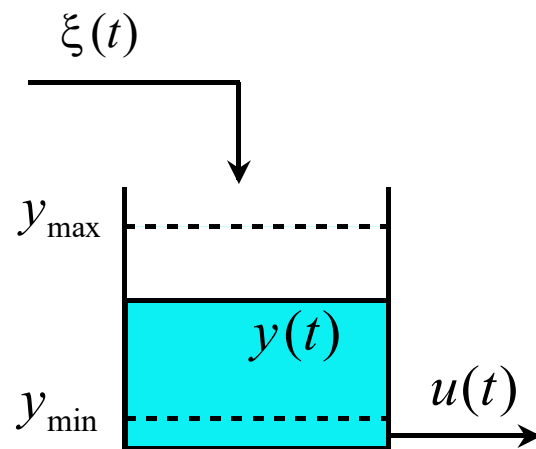
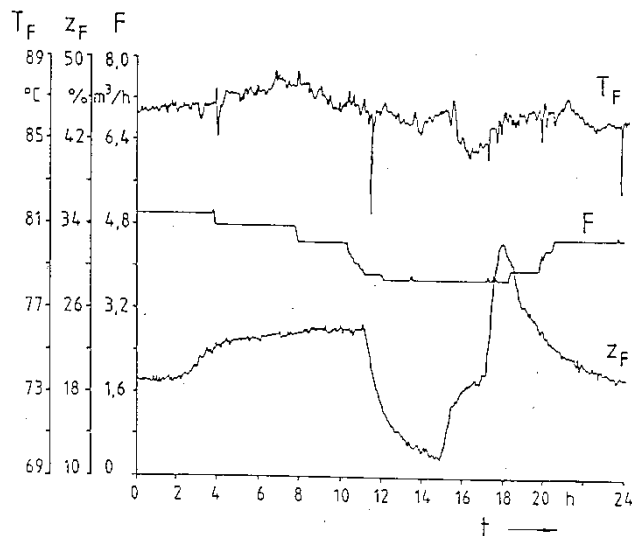

- Feed flow $\xi(t)$ is a stochastic process.
- Outflow $u(t)$ should be as smooth as possible.
- Constraints of the tank level:
upper bound: y_{\max} lower bound: y_{\min}

Discretization in the time horizon:

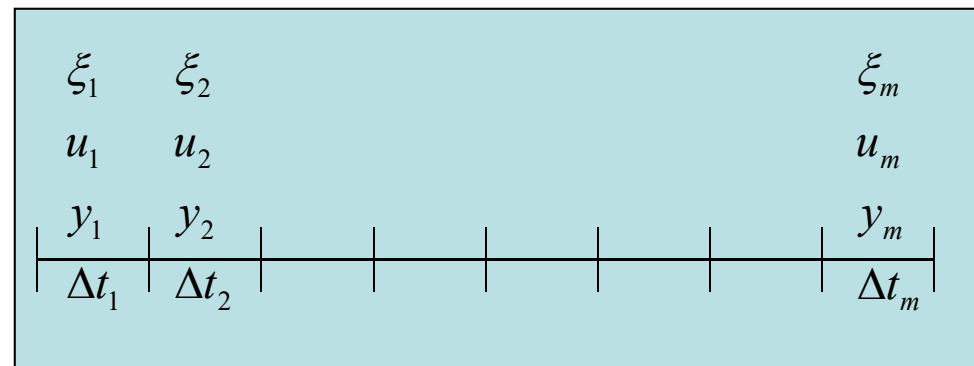

with
$$\Delta t_i = \frac{t_f - t_0}{m}, \quad i = 1, \dots, m$$

Feed tank with an uncertain inflow rate

Mass balance in each time interval: $y_i = y_{i-1} + \xi_i - u_i, \quad i = 1, \dots, m$

u_0 : desired outflow rate

y_0 : initial holdup of the tank

Constraints of holding lower and upper bounds:

$$y_{\min} \leq y_i \leq y_{\max}, \quad i = 1, \dots, m$$

Interval 1: $y_0 + \xi_1 - u_1 \geq y_{\min}, \quad y_0 + \xi_1 - u_1 \leq y_{\max}$

Interval 2: $y_0 + \xi_1 + \xi_2 - u_1 - u_2 \geq y_{\min}, \quad y_0 + \xi_1 + \xi_2 - u_1 - u_2 \leq y_{\max}$

.....

Interval m : $y_0 + \sum_{i=1}^m \xi_i - \sum_{i=1}^m u_i \geq y_{\min}, \quad y_0 + \sum_{i=1}^m \xi_i - \sum_{i=1}^m u_i \leq y_{\max}$

Feed tank with an uncertain inflow rate

The joint chance constrained optimization problem:

$$\begin{aligned} \min \quad & f(\mathbf{y}, \mathbf{u}, \xi) = \sum_{i=1}^m (u_i - u_0)^2 \\ \text{s.t.} \quad & P\{y_i(\mathbf{u}, \xi) \geq y_{\min}, \quad i = 1, \dots, m\} \geq \alpha \\ & P\{y_i(\mathbf{u}, \xi) \leq y_{\max}, \quad i = 1, \dots, m\} \geq \alpha \end{aligned}$$

The solution framework:

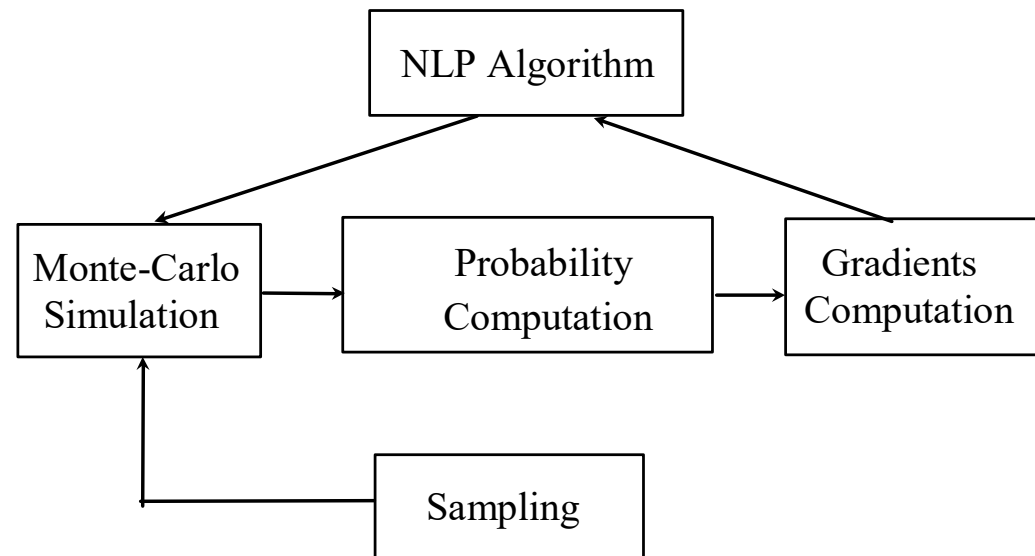

Feed tank with an uncertain inflow rate

Aim of Optimization: Minimization of the oscillations of the feed flow to the column under the tank capacity restriction

10 samples of the total feed flow

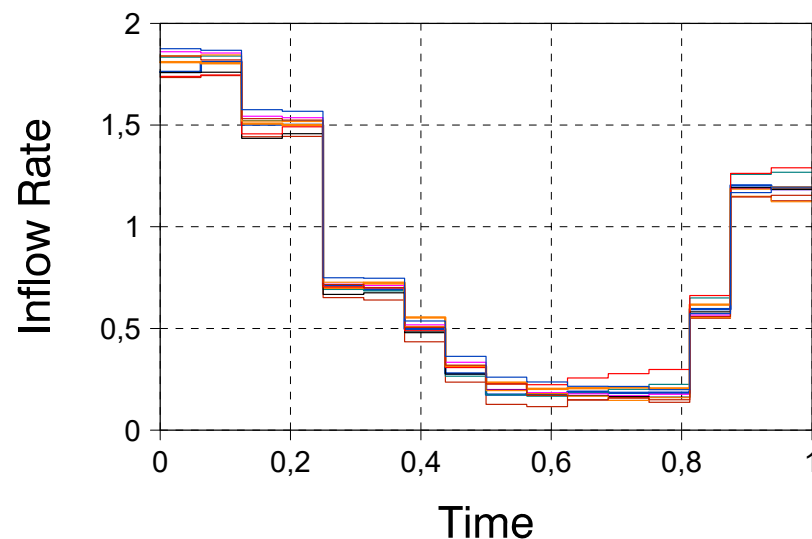

Optimal feed strategy to the column

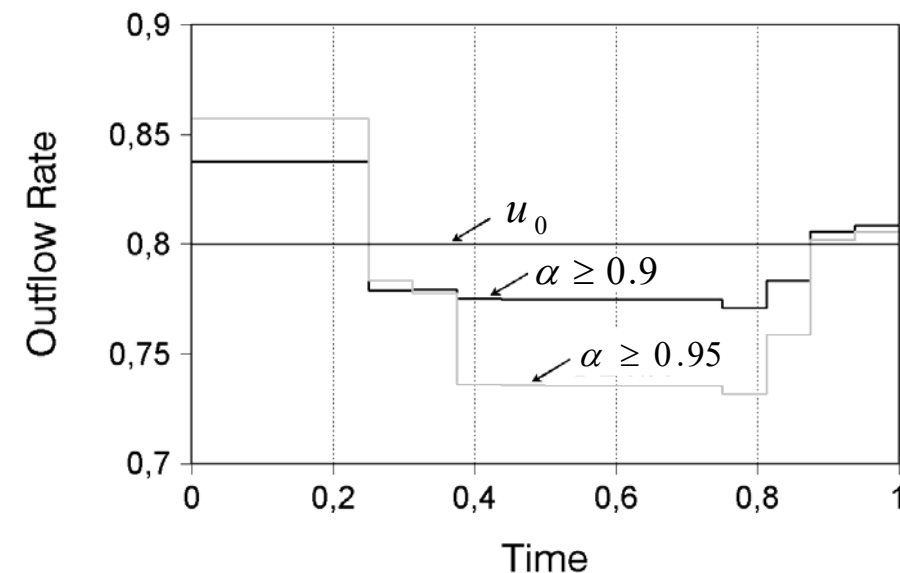

With this determined feed strategy the downstream column operation becomes a **deterministic dynamic optimization** problem.

Feed tank with an uncertain inflow rate

Aim of Optimization: Minimization of the oscillations of the feed flow to the column under the tank capacity restriction

Tank level by 10 disturbances ($\alpha \geq 0.9$)

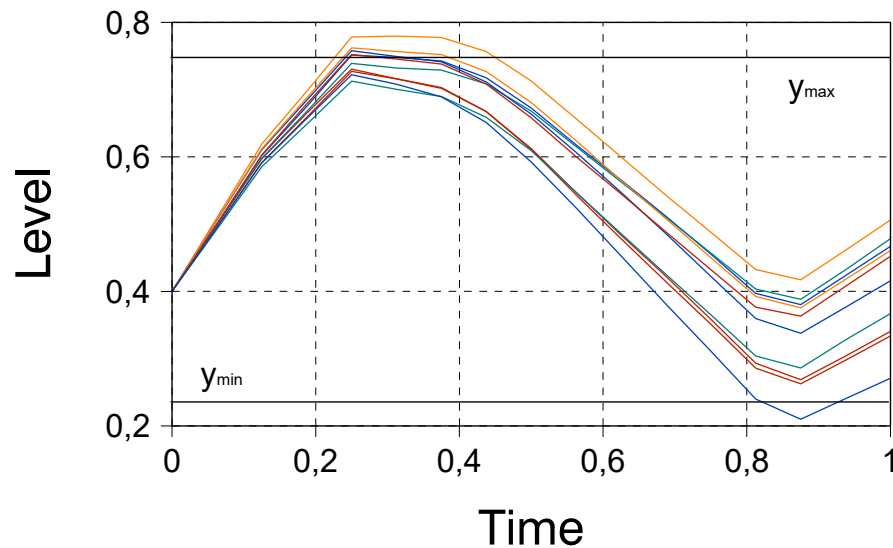

Tank level by 10 disturbances ($\alpha \geq 0.95$)

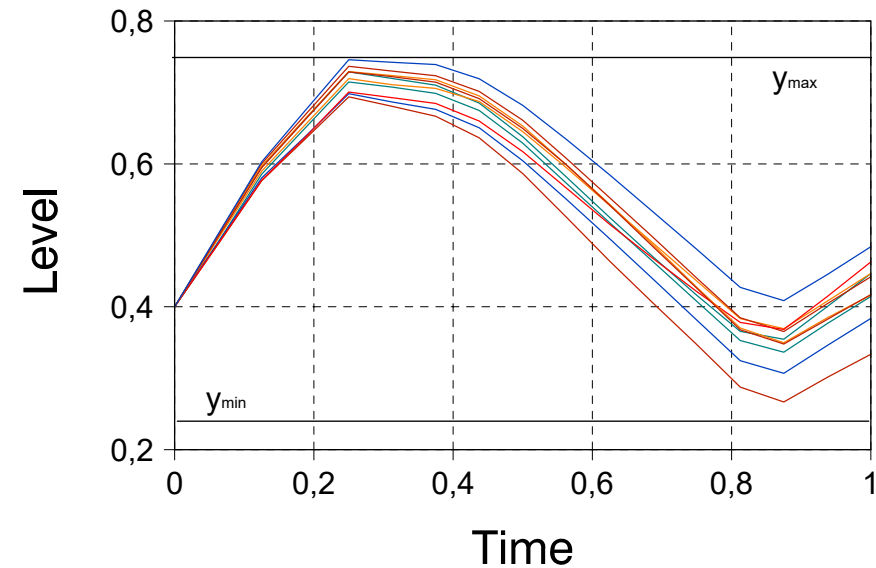

Example: Optimal Production Planning of a Multi-plant Process

Profit maximization under uncertain Supply and product demand

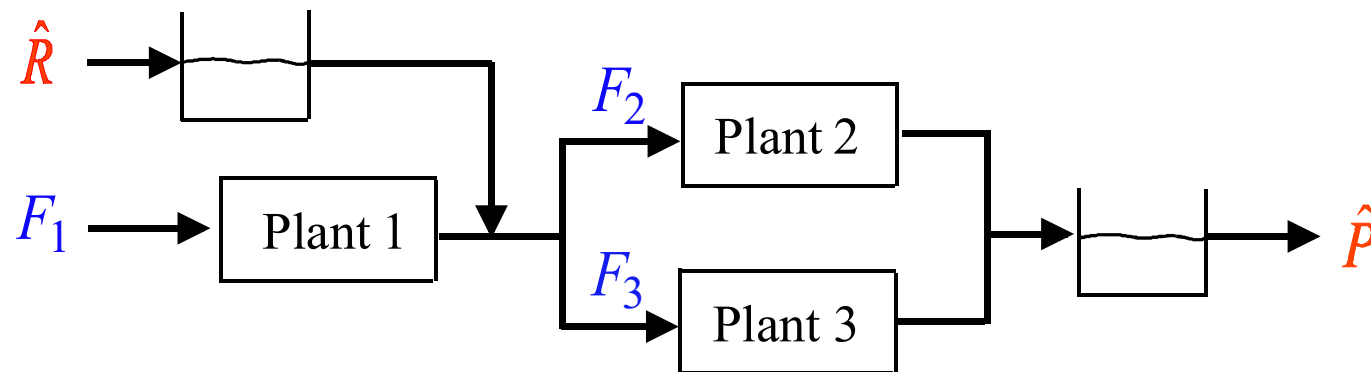

Problem definition:

- Planning the production strategy for the next 5 time period.
- There is the possibility to switch over the plants (structure changes).
- The tank capacity is to be chance constrained.
- Expected values and variances of the uncertain variables are given.
- Expected price factors are known.

A mixed-integer linear optimization problem under chance constraints

Example: Optimal Production Planning of a Multi-plant Process

Profit versus reliability

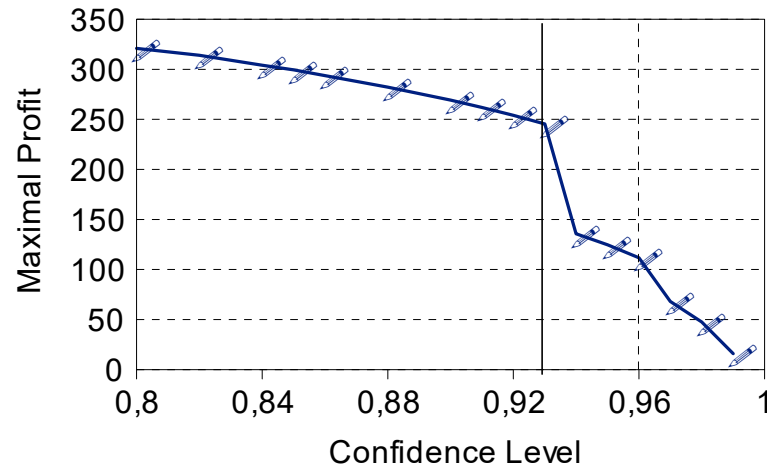

- If α makes a structure change necessary, then there will be a stepwise decrease of the profit.
- This point is suitable for determining optimal decisions for the Production.

On-periods of the plants

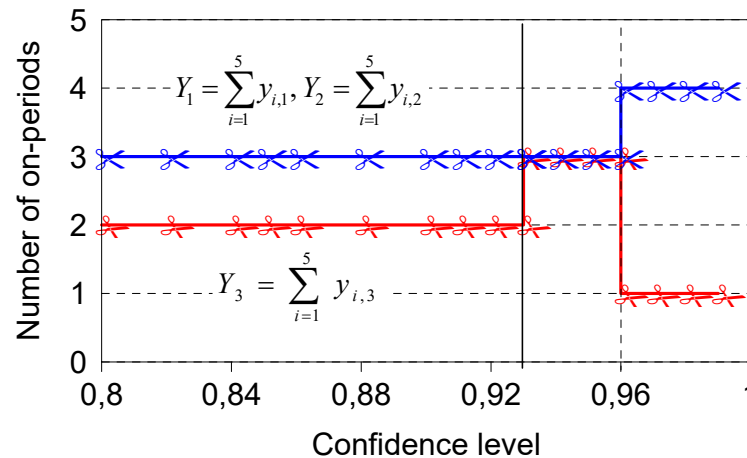

Optimal operation strategy at $\alpha = 0,93$

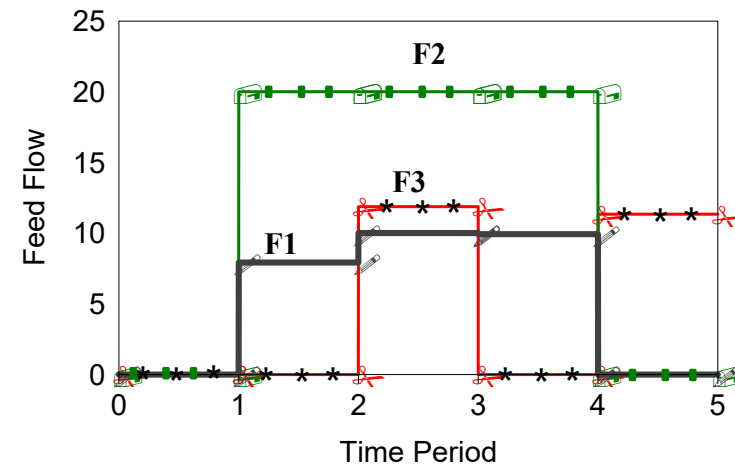

4. Chance constrained MPC

- ▶ **Deterministic Model Predictive Control**
- ▶ **Chance constrained MPC for SISO systems**
- ▶ **Chance constrained MPC for MIMO systems**
- ▶ **Feasibility analysis**

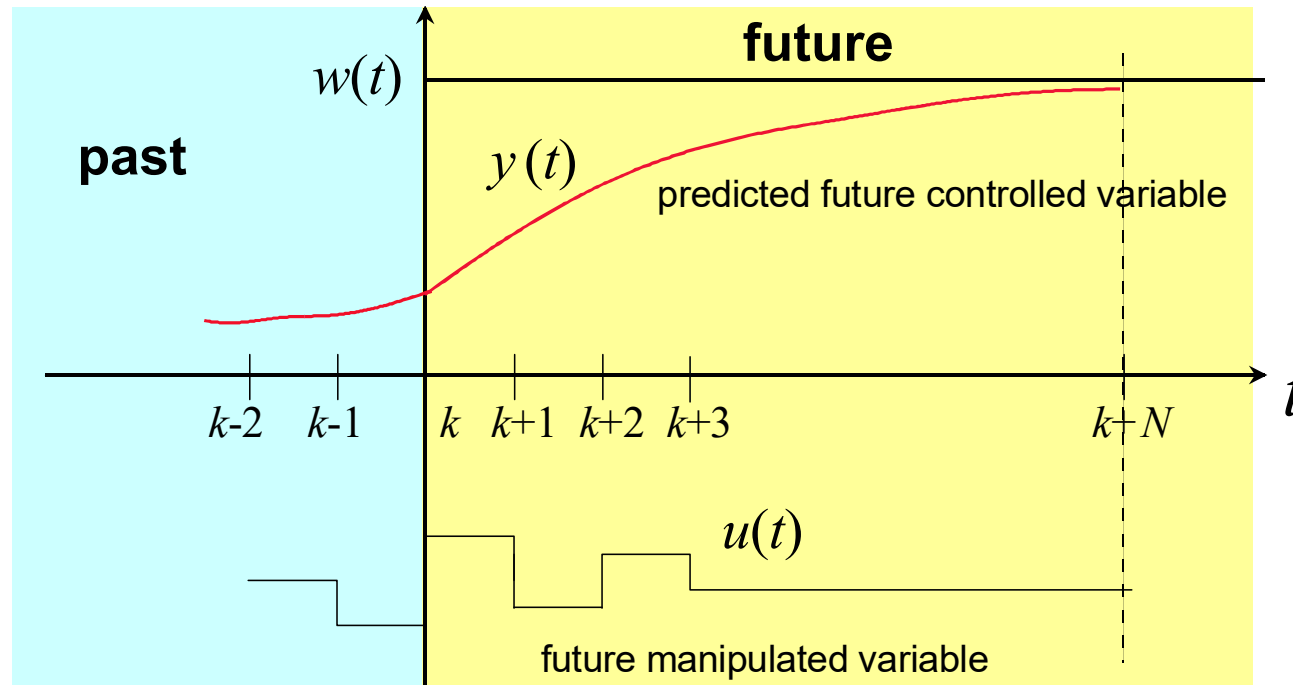

Future controlled variable depends on

- the current state (measured or observed)
- the trajectory of future manipulated variable (to be developed)
- the trajectory of future disturbance (to be **assumed constant !!!**)

The discrete model:

$$A(q^{-1})y(k) = B(q^{-1})u(k) + C(q^{-1})\xi(k)$$

where $A(q^{-1}) = 1 + a_1q^{-1} + \dots + a_{na}q^{-na}$

$$B(q^{-1}) = b_1q^{-1} + \dots + b_{nb}q^{-nb}$$

$$C(q^{-1}) = c_1q^{-1} + \dots + c_{nc}q^{-nc}$$

The uncertain variable in the time horizon

$$\xi \sim N(\boldsymbol{\mu}, \boldsymbol{\Sigma})$$

Input and output constraints:

$$u_{\min} \leq u(k+i) \leq u_{\max}, \quad i = 0, \dots, N-1$$

$$y_{\min}(k+i) \leq y(k+i) \leq y_{\max}(k+i), \quad i = 1, \dots, N$$

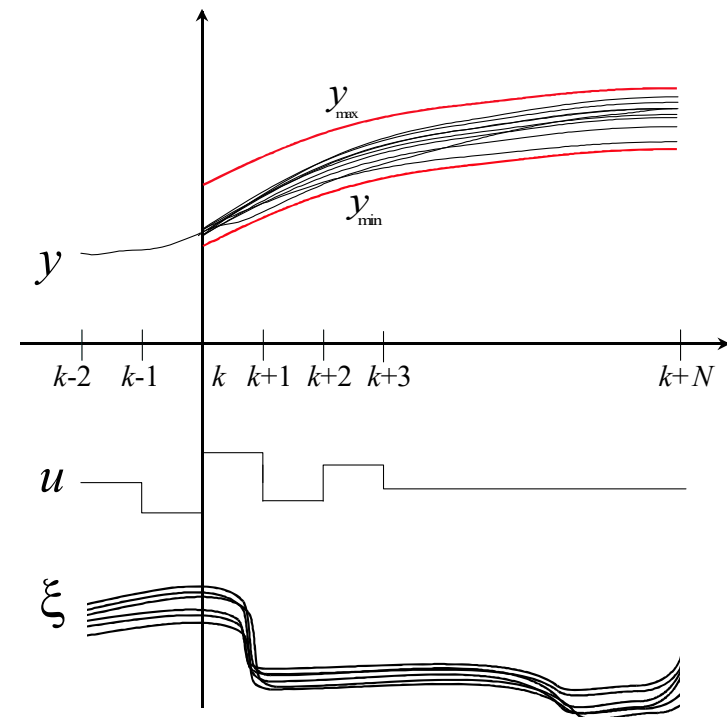

The objective function:

$$\min f(\mathbf{u}) = \sum_{j=1}^N [u(k+j) - u(k+j-1)]^2$$

Single chance constraints:

$$P\{y_{\min}(k+i) \leq y(k+i) \leq y_{\max}(k+i)\} \geq \alpha, \quad i = 1, \dots, N$$

+: Easy to be treated (relaxation to linear inequalities).

–: Correlations between the uncertain variables cannot be dealt with.

Joint chance constraint:

$$P\left\{ \begin{array}{l} y_{\min}(k+1) \leq y(k+1) \leq y_{\max}(k+1) \\ y_{\min}(k+2) \leq y(k+2) \leq y_{\max}(k+2) \\ \dots \\ y_{\min}(k+N) \leq y(k+N) \leq y_{\max}(k+N) \end{array} \right\} \geq \alpha$$

Variables in the future time horizon:

$$\mathbf{y} = [y(k+1), y(k+2), \dots, y(k+N)]^T$$

$$\mathbf{u} = [u(k), u(k+1), \dots, u(k+N-1)]^T$$

$$\boldsymbol{\xi} = [\xi(k), \xi(k+1), \dots, \xi(k+N-1)]^T$$

The model equation leads to

$$\mathbf{y} = \mathbf{G}_1 \mathbf{u} + \mathbf{G}_2 \boldsymbol{\xi}$$

where

$$\mathbf{G}_1 = \begin{bmatrix} g_{11} & 0 & \cdots & 0 \\ g_{12} & g_{11} & \cdots & 0 \\ \cdots & \cdots & \ddots & \cdots \\ g_{1N} & g_{1,N-1} & \cdots & g_{11} \end{bmatrix}, \quad \mathbf{G}_2 = \begin{bmatrix} g_{21} & 0 & \cdots & 0 \\ g_{22} & g_{21} & \cdots & 0 \\ \cdots & \cdots & \ddots & \cdots \\ g_{2N} & g_{2,N-1} & \cdots & g_{21} \end{bmatrix}$$

The joint constraint becomes

$$P\{\mathbf{G}_2 \boldsymbol{\xi} \geq \mathbf{y}_{\min} - \mathbf{G}_1 \mathbf{u}\} \geq \alpha_1$$

$$P\{\mathbf{G}_2 \boldsymbol{\xi} \leq \mathbf{y}_{\max} - \mathbf{G}_1 \mathbf{u}\} \geq \alpha_2$$

Relaxation of the joint chance constraint

Linear transformation: $\xi' = \mathbf{G}_2 \xi$ thus $\xi' \sim N(\mathbf{G}_2 \boldsymbol{\mu}, \mathbf{G}_2 \boldsymbol{\Sigma} \mathbf{G}_2^T)$

Standardization:

$$\xi'' = (\mathbf{G}_2 \boldsymbol{\Sigma} \mathbf{G}_2^T)^{-\frac{1}{2}} (\mathbf{G}_2 \boldsymbol{\mu} - \xi') \quad \text{thus} \quad \xi'' \sim N(\mathbf{0}, \boldsymbol{\Sigma}_S)$$

The joint constraint becomes

$$P\{\xi'' \leq \mathbf{z}_1(\mathbf{u})\} \geq \alpha_1$$

$$P\{\xi'' \leq \mathbf{z}_2(\mathbf{u})\} \geq \alpha_2$$

where $\mathbf{z}_1(\mathbf{u}) = (\mathbf{G}_2 \boldsymbol{\Sigma} \mathbf{G}_2^T)^{-\frac{1}{2}} (-\mathbf{y}_{\min} + \mathbf{G}_1 \mathbf{u} + \mathbf{G}_2 \boldsymbol{\mu})$

$$\mathbf{z}_2(\mathbf{u}) = (\mathbf{G}_2 \boldsymbol{\Sigma} \mathbf{G}_2^T)^{-\frac{1}{2}} (\mathbf{y}_{\max} - \mathbf{G}_1 \mathbf{u} - \mathbf{G}_2 \boldsymbol{\mu})$$

It means

$$\begin{aligned} \Phi[\mathbf{z}_1(\mathbf{u})] &\geq \alpha_1 \\ \Phi[\mathbf{z}_2(\mathbf{u})] &\geq \alpha_2, \end{aligned} \quad \Phi(z_1, \dots, z_N) = P\{\xi_i'' \leq z_i, i = 1, \dots, N\}$$

Repeated solution to realize MPC

- Definition of a moving horizon (N time intervals).
- Optimization of $u(t)$ inside the horizon by SQP.
- Implementing $u(t)$ only in the first interval.
- Re-optimization based on the realization of the random variables.

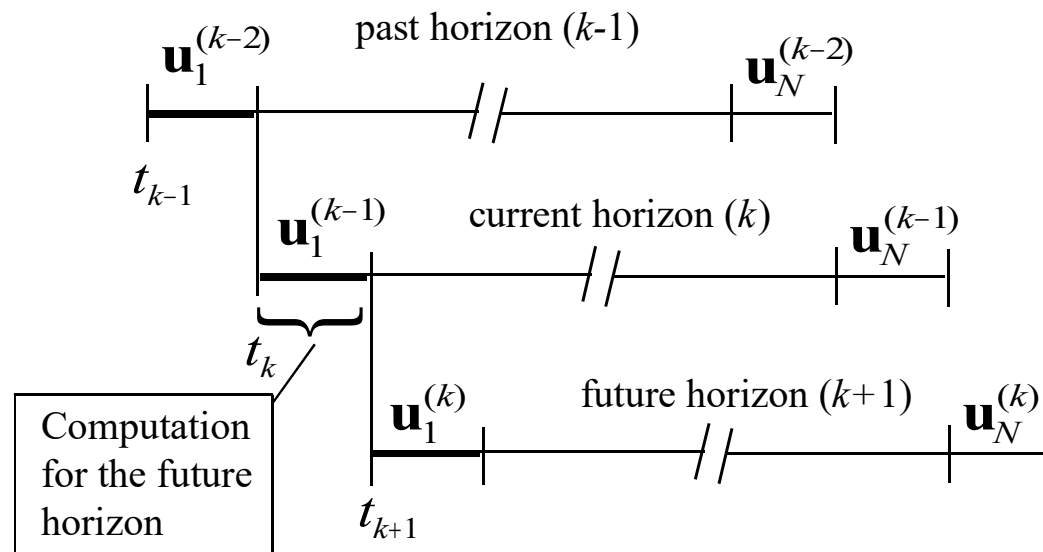

Example: Chance constrained MPC of a tank

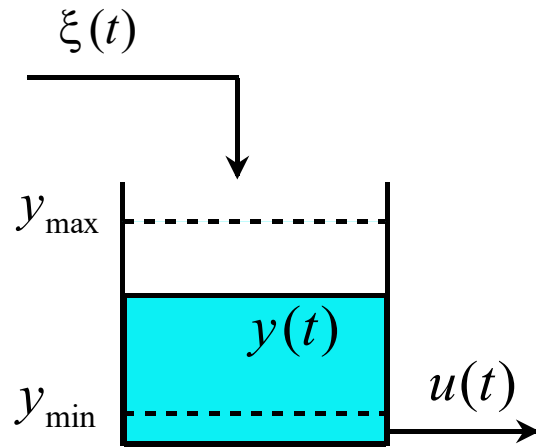

$$\min \quad f(\mathbf{u}) = \sum_{j=1}^6 [u(k+j) - u(k+j-1)]^2$$

$$\text{s.t.} \quad P\{y_i \geq y_{\min}, \quad i = 1, \dots, 6\} \geq \alpha$$

$$P\{y_i \leq y_{\max}, \quad i = 1, \dots, 6\} \geq \alpha$$

Update of the control (deterministic)

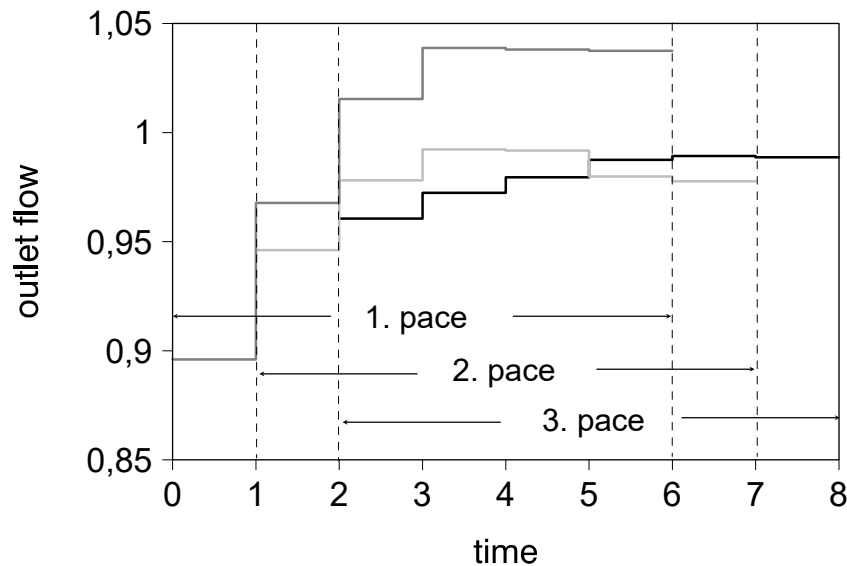

Update of the output (stochastic)

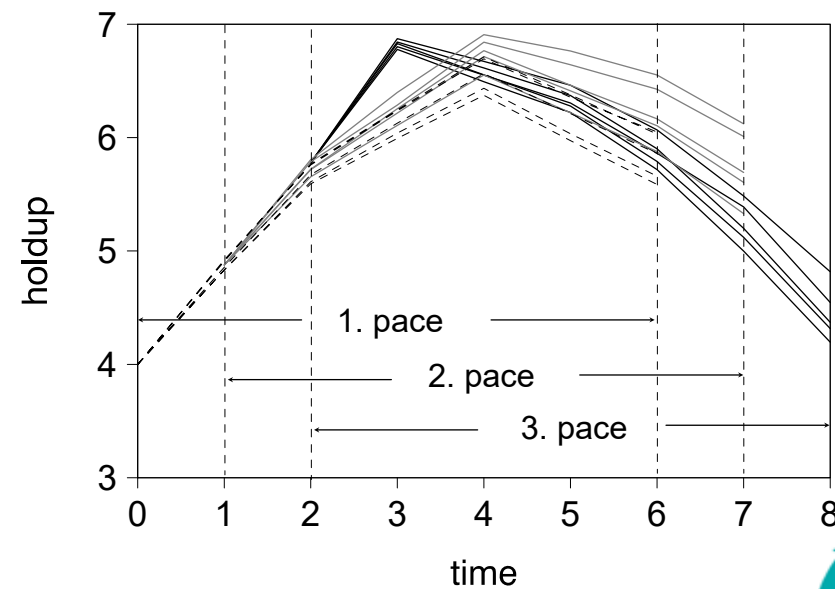

Example: Chance constrained MPC of a tank

Realized profiles of the stochastic MPC

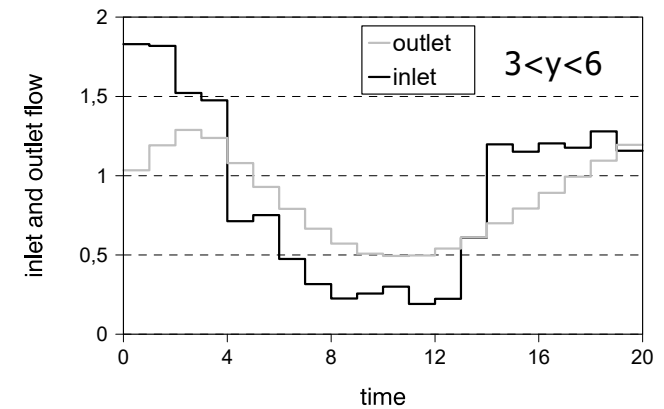
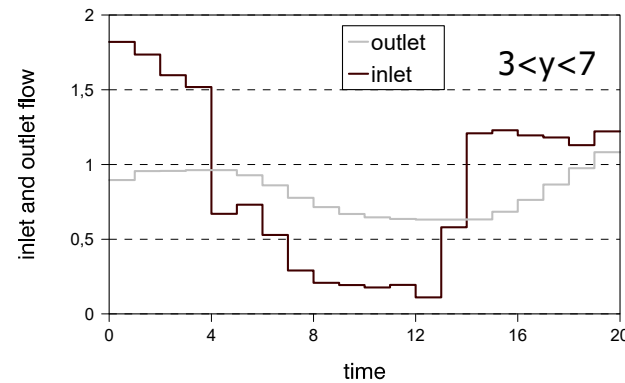
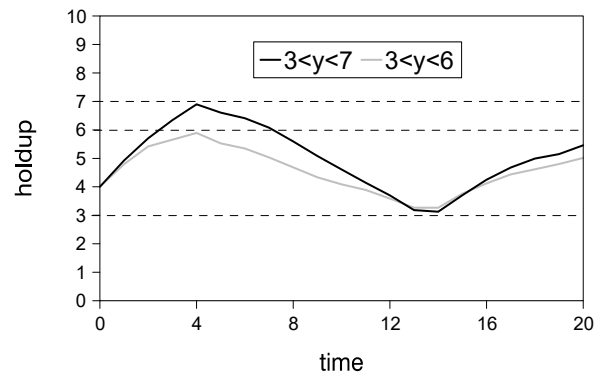

Realized profiles with time dependent output constraints

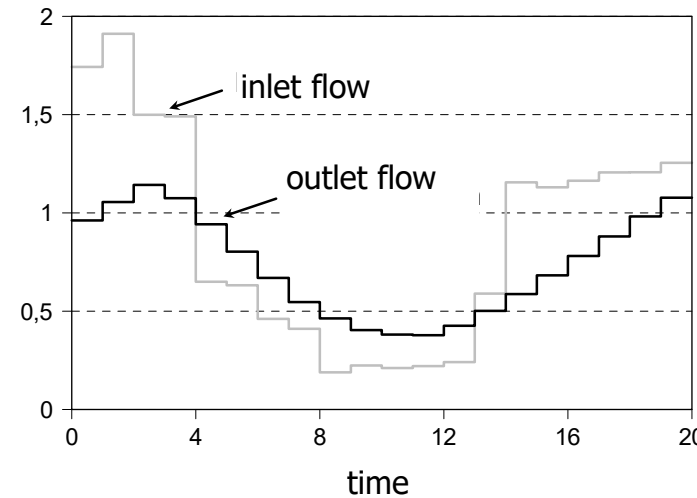
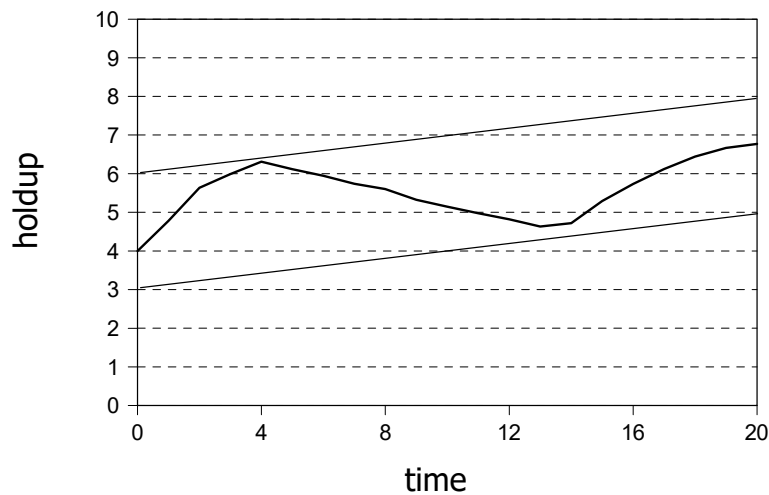

Feasibility analysis:

- The probability level α is predefined.
- Increasing α leads to shrink the feasible region.
- If $\alpha \geq \alpha_{\max}$ (maximum reachable), SQP can not find a solution.
- Calculation of α_{\max} is necessary.
- Previous studies used a maximization step.

Solution approach proposed:

- **The stochastic variables:** $\xi \sim N(\mu, \Sigma)$
- **The output variables:** $y \sim N(\mu_y, \Sigma_y)$
- α_{\max} **depends on** $y(u, \xi)$
- α_{\max} **is maximal if** $\mu_y = (y_{\min} + y_{\max}) / 2$
- **Thus the required u can be computed.**
- **Then α_{\max} can be computed through one run of simulation.**

Probability profiles in respect to the output variable:

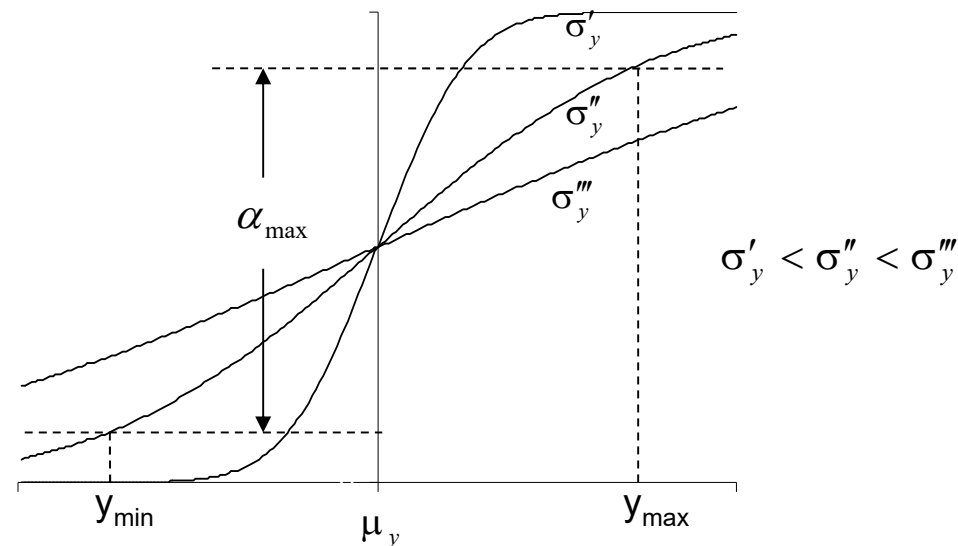

Maximal reachable probability depends on the distribution of uncertain variables

$$\sigma_i = \sigma, r_{ij} = r_{ji} = 1 - \theta j, \quad (i = 1, \dots, N, j = i + 1, \dots, N)$$

	$\sigma = 0.05$	$\sigma = 0.1$	$\sigma = 0.2$
$\theta = 0.05$	$\alpha_{\max} = 0.999$	$\alpha_{\max} = 0.965$	$\alpha_{\max} = 0.805$
$\theta = 0.1$	$\alpha_{\max} = 1.0$	$\alpha_{\max} = 0.986$	$\alpha_{\max} = 0.854$

Multivariable chance constrained MPC

Li et al., Comput. Chem. Eng., 2000, 829-834

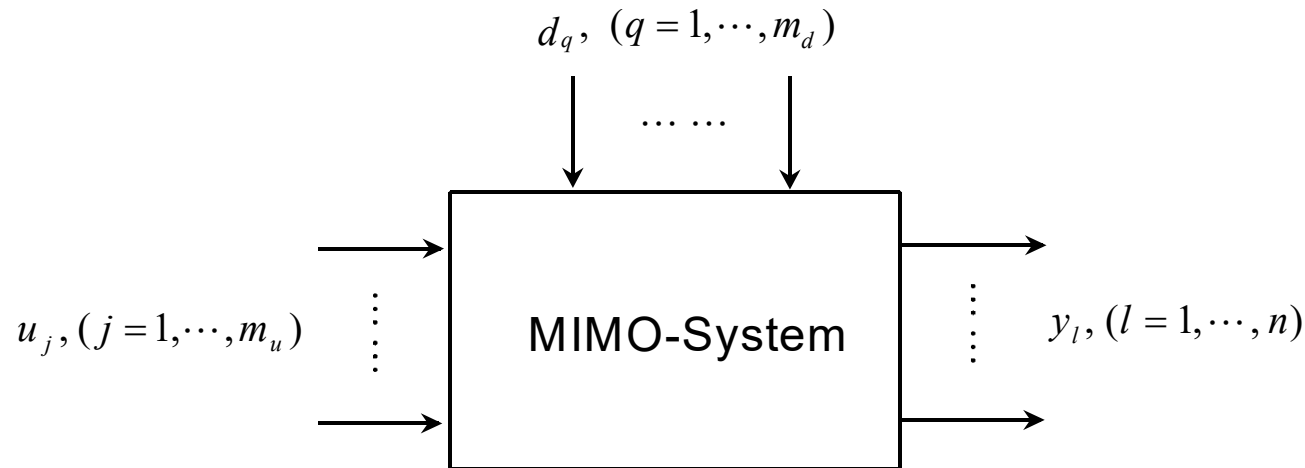

Prediction of future outputs:

$$\mathbf{y}_l(k+i) = \mathbf{y}_l(k) + \sum_{j=1}^{m_u} \mathbf{s}_{l,j} \mathbf{u}_j(k+i) + \sum_{q=1}^{m_d} \mathbf{s}_{l,q} \mathbf{d}_q(k+i) + \sum_{j=1}^{m_u} \mathbf{s}_{l,j} \mathbf{u}_j(k-i) + \sum_{q=1}^{m_d} \mathbf{s}_{l,q} \mathbf{d}_q(k-i)$$

Uncertain variables:

- step-response coefficients $\mathbf{s}_{l,j}$
- future disturbances $\mathbf{d}_q(k+i)$

The control problem:

$$J(N, \mathbf{u}) = \min \sum_{j=1}^{m_u} \sum_{i=1}^N [u_j(k+i) - u_j(k+i-1)]^2$$

subject to joint chance constraints:

$$P \left\{ \begin{array}{l} y_{l,\min} \leq y_l(k+1) \leq y_{l,\max} \\ y_{l,\min} \leq y_l(k+2) \leq y_{l,\max} \\ \dots \\ y_{l,\min} \leq y_l(k+N) \leq y_{l,\max} \end{array} \right\} \geq \alpha_l, \quad l = 1, \dots, n$$

and deterministic constraints:

$$\left[\begin{array}{l} u_{j,\min} \leq u_j(k) \leq u_{j,\max} \\ u_{j,\min} \leq u_j(k+1) \leq u_{j,\max} \\ \dots \\ u_{j,\min} \leq u_j(k+N-1) \leq u_{j,\max} \end{array} \right], \quad j = 1, \dots, m_u$$

Relaxation of the joint chance constraints:

Since $\mathbf{y}_l = [\mathbf{A}_l \mathbf{B}_l] \begin{bmatrix} \mathbf{s} \\ \mathbf{d} \end{bmatrix} + \mathbf{c}_l$ then $\mathbf{y}_l = \mathbf{G}_l \boldsymbol{\xi}_l + \mathbf{c}_l$

where $\boldsymbol{\xi}_l$ has the distribution

$$\boldsymbol{\mu}_l = \begin{bmatrix} \mu_{l1} \\ \mu_{l2} \\ \dots \\ \mu_{lN} \end{bmatrix}, \quad \boldsymbol{\Sigma}_l = \begin{bmatrix} \sigma_{l,1}^2 & \sigma_{l,1}\sigma_{l,2}r_{l,12} & \dots & \sigma_{l,1}\sigma_{l,N}r_{l,1N} \\ \sigma_{l,1}\sigma_{l,2}r_{j,12} & \sigma_{l,2}^2 & \dots & \sigma_{l,2}\sigma_{l,N}r_{l,2N} \\ \dots & \dots & \dots & \dots \\ \sigma_{l,1}\sigma_{j,N}r_{l,1N} & \sigma_{l,2}\sigma_{l,N}r_{l,2N} & \dots & \sigma_{l,N}^2 \end{bmatrix}$$

Standardization of $\boldsymbol{\xi}_l$: $\boldsymbol{\xi}'_l = (\mathbf{G}_l \boldsymbol{\Sigma}_l \mathbf{G}_l^T)^{-\frac{1}{2}} (\mathbf{G}_l \boldsymbol{\mu}_l - \boldsymbol{\xi}_l)$

The relaxed constraints: $\Phi_{l1}(\mathbf{u}) = P\{\boldsymbol{\xi}'_l \leq \boldsymbol{\alpha}_{l1}(\mathbf{u})\} \geq \alpha_l$

$\Phi_{l2}(\mathbf{u}) = P\{\boldsymbol{\xi}'_l \leq \boldsymbol{\alpha}_{l2}(\mathbf{u})\} \geq \alpha_l$

Chance constrained MPC of a distillation column

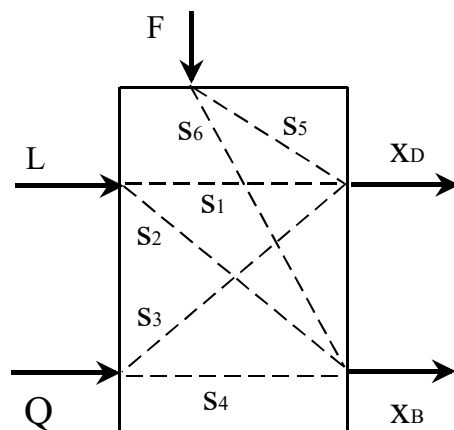
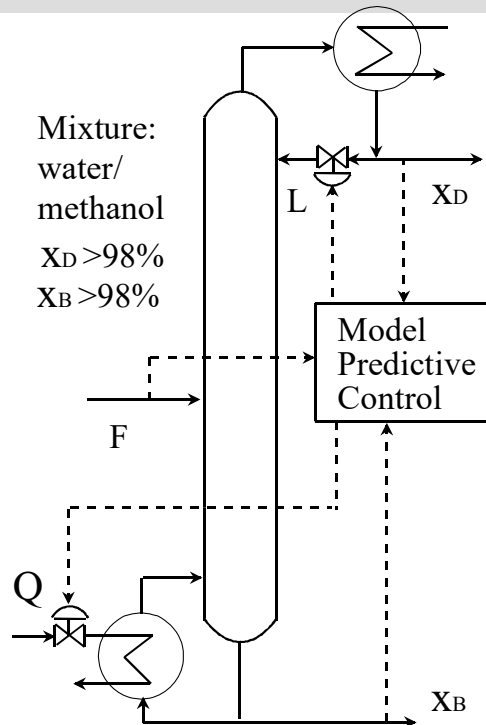

Distillate composition response to reflux flow

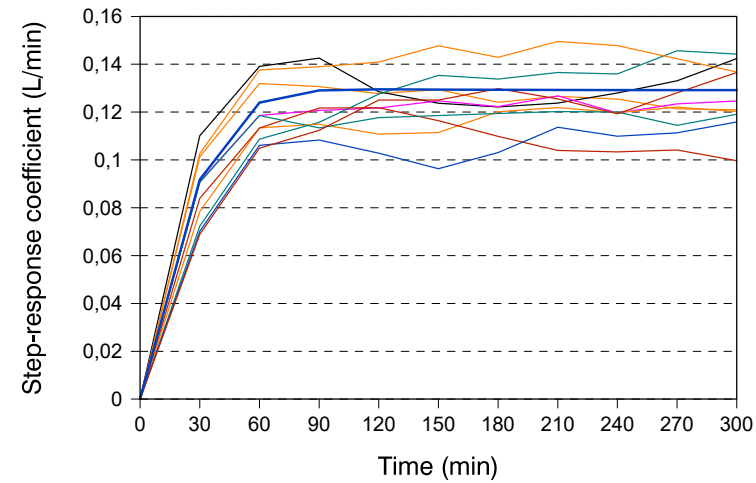

Bottom composition response to reflux flow

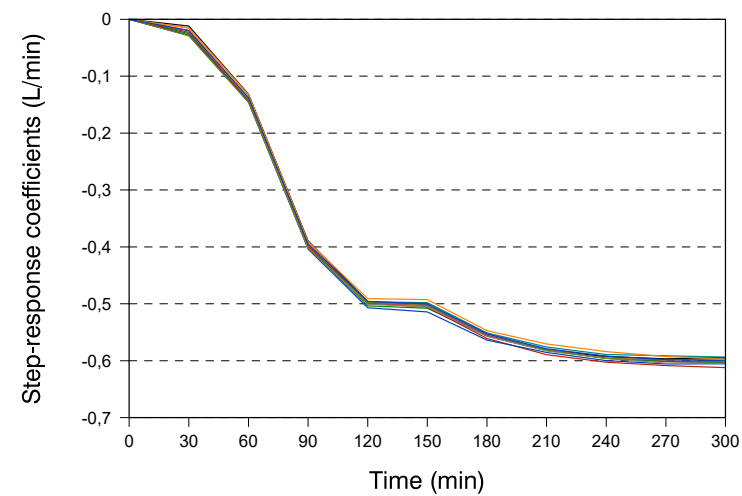

Chance constrained MPC of a distillation column

Uncertain feed flow rate

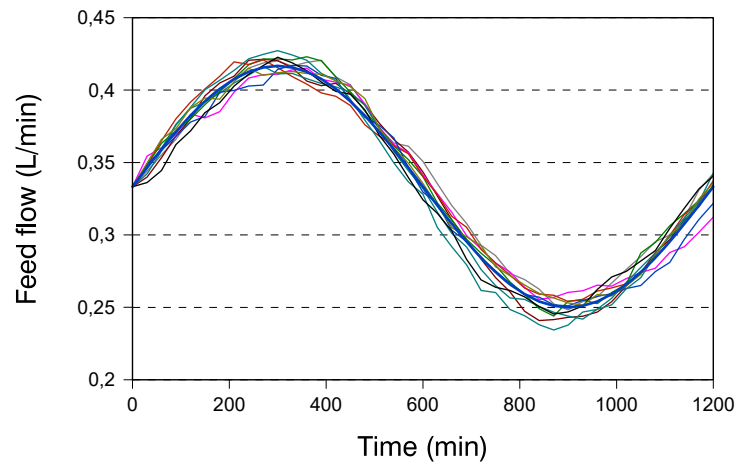

Realized reflux flow rate

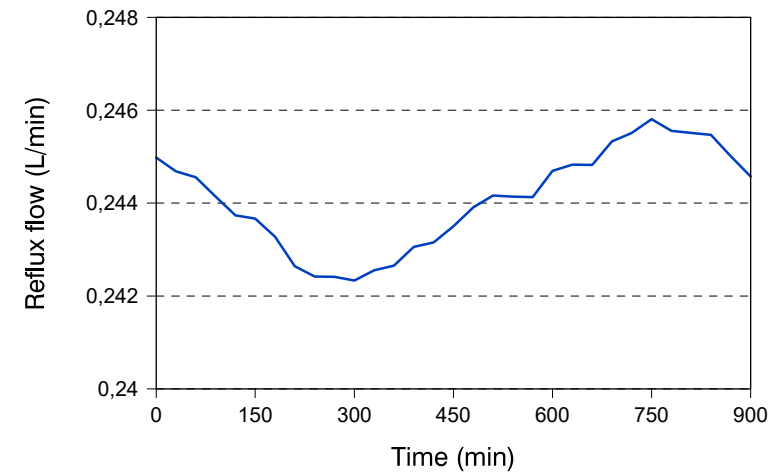

Realized bottom composition

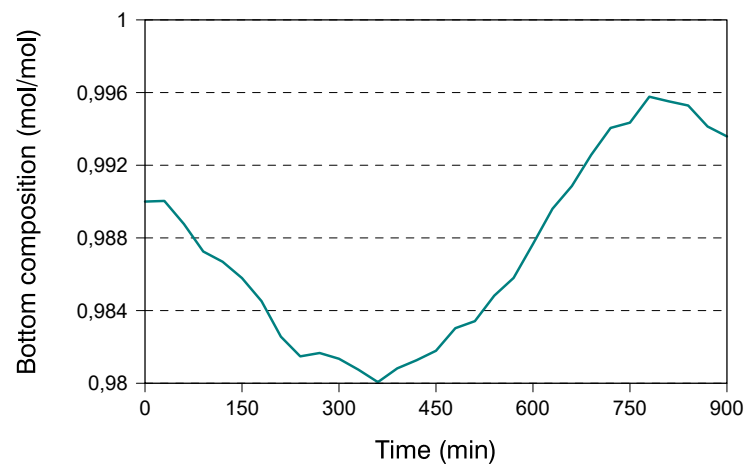

Realized distillate composition

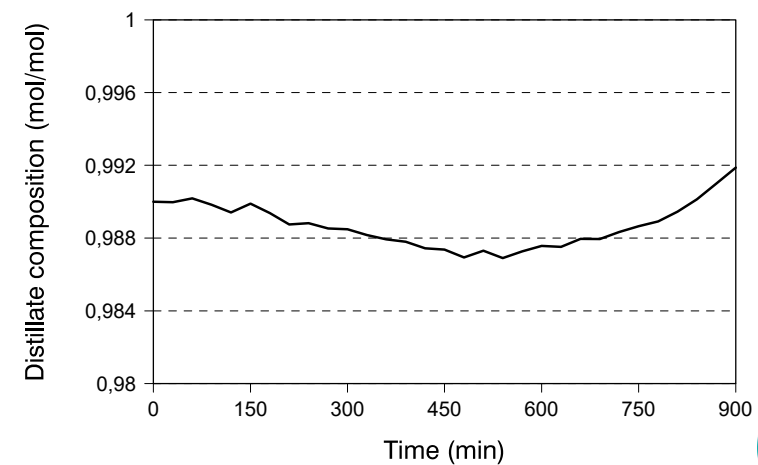

5. Nonlinear chance constrained optimization

- ▶ **Probability computation with inverse mapping**
- ▶ **Numerical implementation**
- ▶ **Open loop and closed-loop optimization**
- ▶ **Optimal design of a reactor system**
- ▶ **Optimal operation of a distillation column**

Nonlinear chance constrained optimization

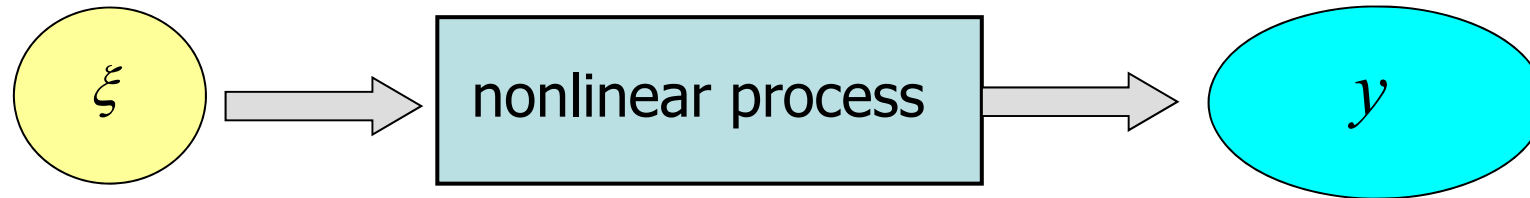

Nonlinear relation between input ξ and output y

How to compute the probability $P\{y \leq y_{\max}\}$?

A direct computation is very difficult.

If there is a monotonic relation, i.e. $\xi \uparrow \Leftrightarrow y \uparrow$

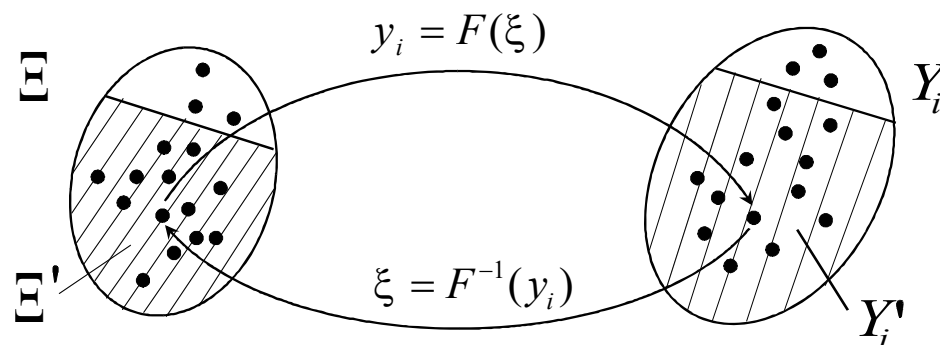

This means
$$P\{y \leq y_{\max}\} = P\{\xi \leq z\}$$

The value at the bound
$$y_{\max} = F(z)$$

Inverse calculation
$$z = F^{-1}(y_{\max})$$

then
$$P\{y \leq y_{\max}\} = P\{\xi \leq z\} = \int_{-\infty}^z \rho(\xi) d\xi$$

Inverse mapping from output to input:

The probability of the **output constraints** can be obtained through computation of the probability of the corresponding constraints of the **input constraints**.

Illustrative example

To compute the probability: $P\{y \leq 30\}$

where $y = \exp(\xi_1 + \xi_2)$

ξ_1, ξ_2 are normally distributed with correlation. Due to the nonlinear relation, we can not achieve the distribution of the output y .

since $\xi_2 \uparrow \Leftrightarrow y \uparrow$

$$P\{y \leq 30\} = P\{\xi_2 \leq -\xi_1 + \ln 30\}$$

We can compute the probability in the input domain:

$$P\{y \leq 30\} = \int_{-\infty}^{\infty} \int_{-\infty}^{-\xi_1 + \ln 30} \rho(\xi_1, \xi_2) d\xi_2 d\xi_1$$

Illustrative example

Parameters of the uncertain inputs in the illustrative example

	Expected value	Standard deviation	Correlation matrix
ξ_1	1.0	0.2	$\begin{bmatrix} 1.0 & 0.5 \\ 0.5 & 1.0 \end{bmatrix}$
ξ_2	2.0	0.3	

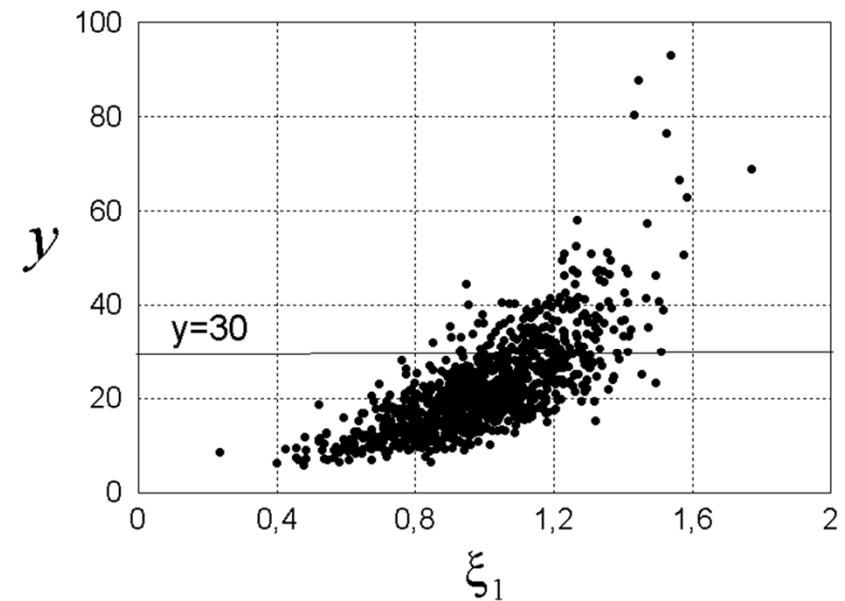
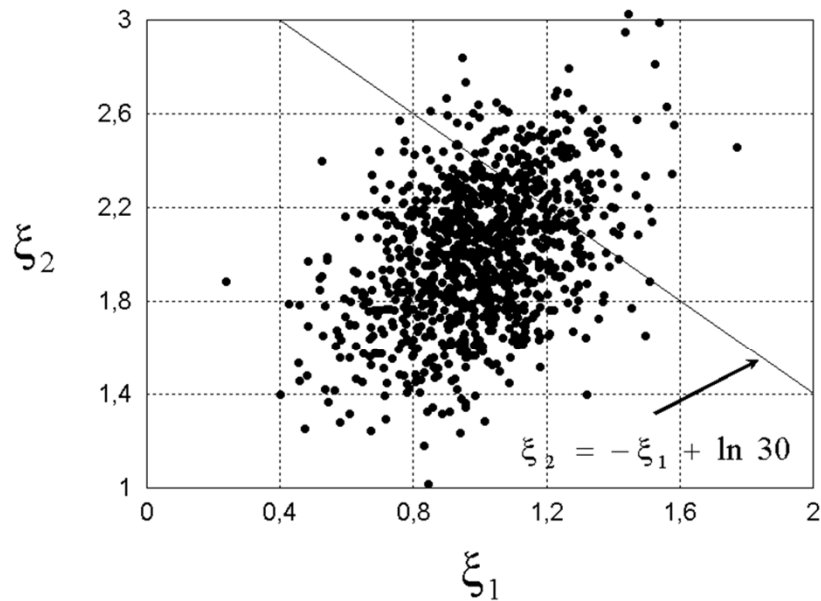

Nonlinear chance constraints

For problems with multivariate uncertain inputs:

$$y_i = F(\xi_1, \xi_2, \dots, \xi_m, \mathbf{u}) \quad \text{and} \quad P\{y_i \leq y_i^{\max}\} = ?$$

We have to find an input ξ_m that is monotonic with y_i

The reverse function: $z_{\max} = F^{-1}(\xi_1, \dots, \xi_{m-1}, y_i^{\max}, \mathbf{u})$

then
$$P\{y_i \leq y_i^{\max}\} = P\{\xi_m \leq z_{\max}\}$$

Probability and gradient computation:

$$P\{y_i \leq y_i^{\max}\} = \int_{-\infty}^{\infty} \dots \int_{-\infty}^{\infty} \int_{-\infty}^{z_{\max}(\xi_1, \xi_2, \dots, \xi_{m-1}, \mathbf{u})} \rho(\xi_1, \dots, \xi_{m-1}, \xi_m) d\xi_m d\xi_{m-1} \dots d\xi_1$$

$$\frac{\partial P\{y_i \leq y_i^{\max}\}}{\partial \mathbf{u}} = \int_{-\infty}^{\infty} \dots \int_{-\infty}^{\infty} \rho(\xi_1, \dots, \xi_{m-1}, z_{\max}) \frac{\partial z_{\max}}{\partial \mathbf{u}} d\xi_{m-1} \dots d\xi_1$$

Gradient computation using the Implicit Function Theorem:

since

$$\frac{\partial P\{y_i \leq y_i^{\max}\}}{\partial \mathbf{u}} = \int_{-\infty}^{\infty} \cdots \int_{-\infty}^{\infty} \rho(\xi_1, \dots, \xi_{m-1}, z_{\max}) \frac{\partial z_{\max}}{\partial \mathbf{u}} d\xi_{m-1} \cdots d\xi_1$$

Usually we have the implicit form of nonlinear equations:

$$\mathbf{g}(\xi_1, \dots, \xi_{m-1}, z_{\max}, y_i^{\max}, \mathbf{u}) = \mathbf{0}$$

The gradient can be computed by

$$\frac{\partial z_{\max}}{\partial \mathbf{u}} = - \left(\frac{\partial \mathbf{g}}{\partial z_{\max}} \right)^{-1} \left(\frac{\partial \mathbf{g}}{\partial \mathbf{u}} \right)$$

This can be computed beforehand, so that the computation time can be reduced.

The impact of control variable:

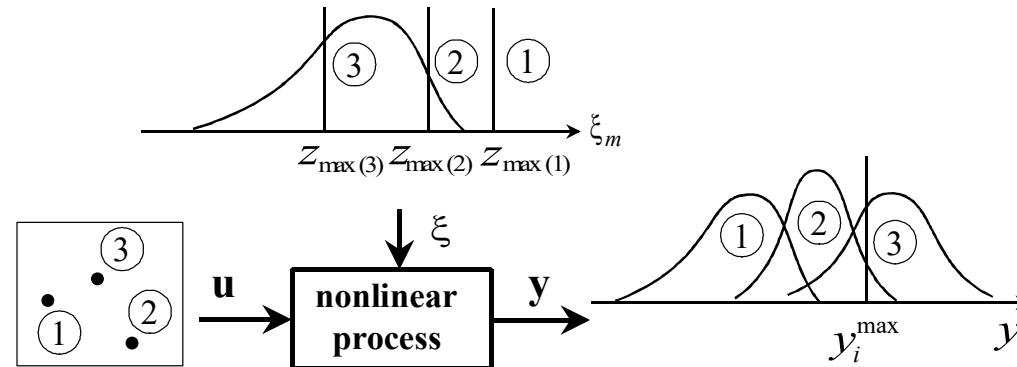

For problems with *joint* constraints:

$$y_i = F(\xi_1, \xi_2, \dots, \xi_m, \mathbf{u}) \quad \text{and} \quad P\{y_i^{\min} \leq y_i \leq y_i^{\max}\} = ?$$

If there exists $\xi_m \uparrow \Rightarrow y_i \uparrow$ then

$$z_{\max} = F^{-1}(\xi_1, \dots, \xi_{m-1}, y_i^{\max}, \mathbf{u}), \quad z_{\min} = F^{-1}(\xi_1, \dots, \xi_{m-1}, y_i^{\min}, \mathbf{u})$$

$$P\{y_i^{\min} \leq y_i \leq y_i^{\max}\} = \int_{-\infty}^{\infty} \dots \int_{-\infty}^{\infty} \int_{z_{\min}(\xi_1, \dots, \xi_{m-1}, \mathbf{u})}^{z_{\max}(\xi_1, \dots, \xi_{m-1}, \mathbf{u})} \rho(\xi_1, \dots, \xi_{m-1}, \xi_m) d\xi_m d\xi_{m-1} \dots d\xi_1$$

Computation framework (a sequential approach):

The most difficult task to solve this problem is the multivariate integration for the probability and gradient computation.

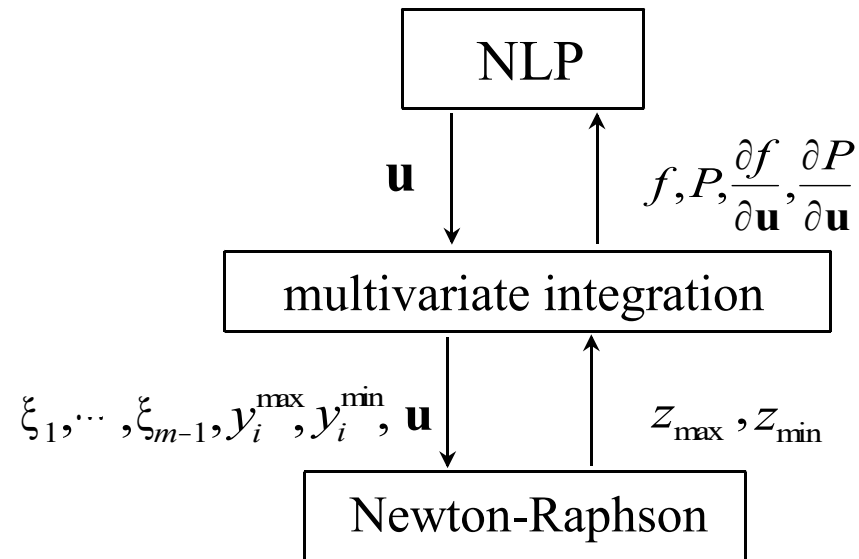

The maximum reachable probability level:

$$\begin{aligned} & \max_{\mathbf{u}, \alpha} \alpha \\ & \text{s.t. } P\{y_i^{\min} \leq y_i \leq y_i^{\max}\} \geq \alpha, \quad i = 1, \dots, I \\ & \mathbf{u}_{\min} \leq \mathbf{u} \leq \mathbf{u}_{\max} \end{aligned}$$

The solution of this problem provides α_{\max} . For any $\alpha \leq \alpha_{\max}$ we have a nonempty feasible region, i.e. a solution will be ensured.

Consider *standard* multivariate normal distribution $\xi \sim N(\mathbf{0}, \Sigma)$

For the numerical integration, collocation on finite elements is chosen to discretize this density function.

On the collocation points of each integral (z_1, \dots, z_m)

we need to compute

$$\Phi_m(z_1, \dots, z_m, \Sigma) = \int_{-\infty}^{z_1} \cdots \int_{-\infty}^{z_m} \rho_m(\xi_1, \dots, \xi_m) d\xi_1 \cdots d\xi_m$$

since

$$\Phi_m(z_1, \dots, z_m, \Sigma) = \int_{-\infty}^{z_1} \Phi_{m-1}(z_2^{(1)}, \dots, z_m^{(1)}, \Sigma^{(1)}) \rho_1(\xi_1) d\xi_1$$

where

$$z_k^{(1)} = \frac{z_k - r_{k,1}\xi_1}{\sqrt{1 - r_{k,1}^2}}, \quad k = 2, \dots, m \quad \text{and} \quad r_{i,j}^{(1)} = \frac{r_{i,j} - r_{i,1}r_{j,1}}{\sqrt{1 - r_{i,1}^2}\sqrt{1 - r_{j,1}^2}}, \quad i, j = 2, \dots, m$$

Now we have to compute $m-1$ dimensional integral

$$\Phi_{m-1}(z_2^{(1)}, \dots, z_m^{(1)}, \Sigma^{(1)}) = \int_{-\infty}^{z_2^{(1)}} \cdots \int_{-\infty}^{z_m^{(1)}} \rho_{m-1}(\xi_2, \dots, \xi_m) d\xi_2 \cdots d\xi_m$$

Numerical multivariate integration

Continuing this procedure for $m-2$ steps, we arrive at the 2-dimensional integral

$$\Phi_2(z_{m-1}^{(m-2)}, z_m^{(m-2)}, \Sigma^{(m-2)}) = \int_{-\infty}^{z_{m-1}^{(m-2)}} \int_{-\infty}^{z_m^{(m-2)}} \rho_2(\xi_{m-1}, \xi_m) d\xi_{m-1} d\xi_m$$

This can be further reduced to

$$\Phi_2(z_{m-1}^{(m-2)}, z_m^{(m-2)}, \Sigma^{(m-2)}) = \int_{-\infty}^{z_{m-1}^{(m-2)}} \Phi_1 \left[\frac{z_m^{(m-2)} - r_{1,2}^{(m-2)} \xi_{m-1}}{\sqrt{1 - (r_{1,2}^{(m-2)})^2}} \right] \rho_1(\xi_{m-1}) d\xi_{m-1}$$

This last step can be computed using subroutine of available software.

For normal standard distribution $P\{|\xi| < 3\} \approx 0,9973$ we can use

$-\infty \approx -3$
$+\infty \approx +3$

To increase the integration accuracy we can

- increase the number of elements
- increase the number of collocation points

A proper compromise between accuracy and expanse has to be found.

Gradient computation:

$$\frac{\partial \Phi_m}{\partial \mathbf{u}} = \int_{-\infty}^{z_1} \frac{\partial \Phi_{m-1}}{\partial \mathbf{u}} \rho_1(\xi_1) d\xi_1$$

Since
$$\Phi_{m-1}(z_2^{(1)}, \dots, z_S^{(1)}, \Sigma^{(1)}) = \int_{-\infty}^{z_2^{(1)}} \Phi_{m-2}(z_3^{(2)}, \dots, z_m^{(2)}, \Sigma^{(2)}) \rho_1(\xi_2) d\xi_2$$

it follows

$$\frac{\partial \Phi_{m-1}}{\partial \mathbf{u}} = \int_{-\infty}^{z_2^{(1)}} \frac{\partial \Phi_{m-2}}{\partial \mathbf{u}} \rho_1(\xi_2) d\xi_2$$

Continuing this procedure for $m-2$ steps we arrive at

$$\frac{\partial \Phi_2}{\partial \mathbf{u}} = \int_{-\infty}^{z_{m-1}^{(m-2)}} \frac{\partial \Phi_1}{\partial \mathbf{u}} \rho_1(\xi_{m-1}) d\xi_{m-1}$$

and

$$\frac{\partial \Phi_1}{\partial \mathbf{u}} = \rho_1(z_m^{(m-1)}) \frac{\partial z_m^{(m-1)}}{\partial \mathbf{u}}$$

Quasi-concave function: $f(\mathbf{x})$

For each pair $\mathbf{x}_1, \mathbf{x}_2 \in C$ and C is convex, with $0 \leq \lambda \leq 1$

$$f[\lambda \mathbf{x}_1 + (1 - \lambda) \mathbf{x}_2] \geq \min [f(\mathbf{x}_1), f(\mathbf{x}_2)]$$

A feature of a quasi-concave function is that the region

$\{\mathbf{x} \mid f(\mathbf{x}) \geq b, -\infty < b < \infty\}$
convex.

Log-concave function: $f(\mathbf{x})$

For $f(\mathbf{x}) > 0$ and $0 < \lambda < 1$

$$f[\lambda \mathbf{x}_1 + (1 - \lambda) \mathbf{x}_2] \geq [f(\mathbf{x}_1)]^\lambda [f(\mathbf{x}_2)]^{1-\lambda}$$

that is $\ln f[\lambda \mathbf{x}_1 + (1 - \lambda) \mathbf{x}_2] \geq \lambda \ln [f(\mathbf{x}_1)] + (1 - \lambda) \ln [f(\mathbf{x}_2)]$

Since $[f(\mathbf{x}_1)]^\lambda [f(\mathbf{x}_2)]^{1-\lambda} \geq \min [f(\mathbf{x}_1), f(\mathbf{x}_2)]$

A log-concave function is also quasi-concave.

A further feature is that the integration of a log-concave function

$$g(\mathbf{x}) = \int f(\mathbf{x}, \mathbf{y}) d\mathbf{y}$$

is log-concave.

Convexity of chance constraints:

We consider multivariate normal distribution

$$\rho_m(\xi) = \frac{1}{\sqrt{(2\pi)^m \det(\Sigma)}} \exp\left[-\frac{1}{2}(\xi - \mu)^T \Sigma^{-1}(\xi - \mu)\right]$$

$$\ln \rho_m(\xi) = -\frac{1}{2}(\xi - \mu)^T \Sigma^{-1}(\xi - \mu) - \ln \sqrt{(2\pi)^m \det(\Sigma)}$$

Since $-\frac{1}{2}(\xi - \mu)^T \Sigma^{-1}(\xi - \mu)$ is concave, $\rho_m(\xi)$ is log-concave, and then

$$\Phi_m(z_1, \dots, z_m, \Sigma) = \int_{-\infty}^{z_1} \dots \int_{-\infty}^{z_m} \rho_m(\xi_1, \dots, \xi_m) d\xi_1 \dots d\xi_m$$

is log-concave.

Convexity analysis of chance constraints

It means $\Phi_m(z_1, \dots, z_m, \Sigma) = P\{\xi_1 \leq z_1, \dots, \xi_m \leq z_m\}$ is log-concave and thus quasi-concave. Therefore

$$P\{\xi_1 \leq z_1, \dots, \xi_m \leq z_m\} \geq \alpha$$

builds a convex set.

After a linear transformation the following chance constraint

$$P\{\xi \leq \mathbf{A}\mathbf{z} + \mathbf{b}\} \geq \alpha$$

also builds a convex set.

In the nonlinear case it can be proved that the probability function

$$F(\mathbf{z}) = P\{h_i(\mathbf{z}, \xi) \geq 0, \quad i = 1, \dots, l\}$$

is quasi-concave, if the functions $h_i(\mathbf{z}, \xi), (i = 1, \dots, l)$ are log-concave.

Then

$$P\{h_i(\mathbf{z}, \xi) \geq 0, \quad i = 1, \dots, l\} \geq \alpha$$

forms a convex set.

Example: optimal design of a reactor system

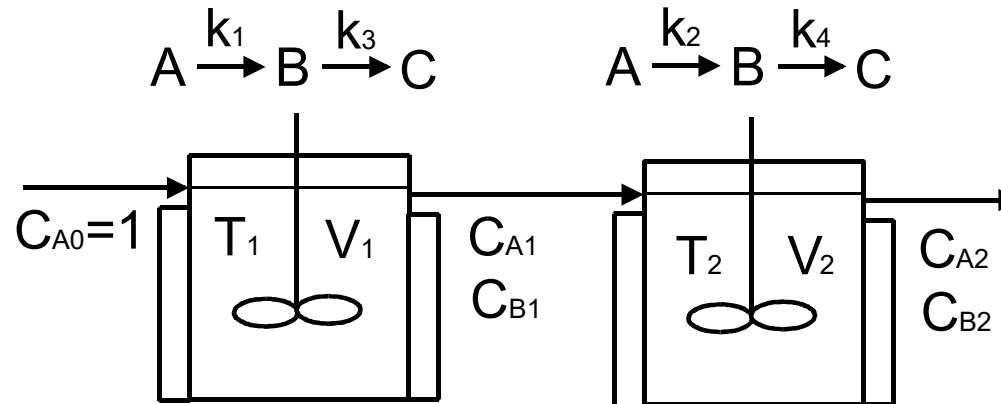

Uncertain kinetic parameters in the Arrhenius equation:

$$k_1 = k_{10} e^{-E_1/RT_1}, \quad k_2 = k_{10} e^{-E_1/RT_2}$$

$$k_3 = k_{20} e^{-E_2/RT_1}, \quad k_4 = k_{20} e^{-E_2/RT_2}$$

	Expected value	Standard deviation	Correlation matrix
E_1	6665.948	200	$\begin{bmatrix} 1 & 0.5 & 0.3 & 0.2 \\ 0.5 & 1 & 0.5 & 0.1 \\ 0.3 & 0.5 & 1 & 0.3 \\ 0.2 & 0.1 & 0.3 & 1 \end{bmatrix}$
E_2	7965.248	240	
k_{10}	0.715	0.0215	
k_{20}	0.182	0.0055	

The optimization problem:

Cost minimization of the reactors under constraint to hold the product specification.

The equality constraints are the mass balances of both reactors and the Arrhenius equations.

It leads to an nonlinear optimization problem under chance constraints.

$$\begin{aligned} \min \quad & f = \sqrt{V_1} + \sqrt{V_2} \\ \text{s.t.} \quad & C_{A1} + k_1 C_{A2} V_1 = 1 \\ & C_{A2} - C_{A1} + k_2 C_{A2} V_2 = 0 \\ & C_{B1} + C_{A1} + k_3 C_{B1} V_1 = 1 \\ & C_{B2} - C_{B1} + C_{A2} - C_{A1} + k_4 C_{B2} V_2 = 0 \\ & k_1 = k_{10} e^{-E_1/RT_1} \\ & k_2 = k_{10} e^{-E_1/RT_2} \\ & k_3 = k_{20} e^{-E_2/RT_1} \\ & k_4 = k_{20} e^{-E_2/RT_2} \\ & P\{C_{B2} \geq C_{B2}^{SP}\} \geq \alpha \\ & 0 \leq V_1, V_2 \leq 16 \end{aligned}$$

Example: optimal design of a reactor system

The optimization results:

C_{B2}^{SP}	α	V_1		V_2		f	
		ST	DT	ST	DT	ST	DT
0.50	0.90	3.301	3.222	3.266	2.814	3.624	3.472
0.50	0.95	3.497	--	3.245	--	3.671	--
0.52	0.90	3.808	3.452	3.795	3.416	3.899	3.706
0.52	0.95	3.854	--	4.001	--	3.963	--
0.54	0.90	4.474	3.910	4.908	4.168	4.331	4.019
0.54	0.95	4.701	--	5.439	--	4.501	--

ST: stochastic

DT: deterministic

Case 1: deterministic

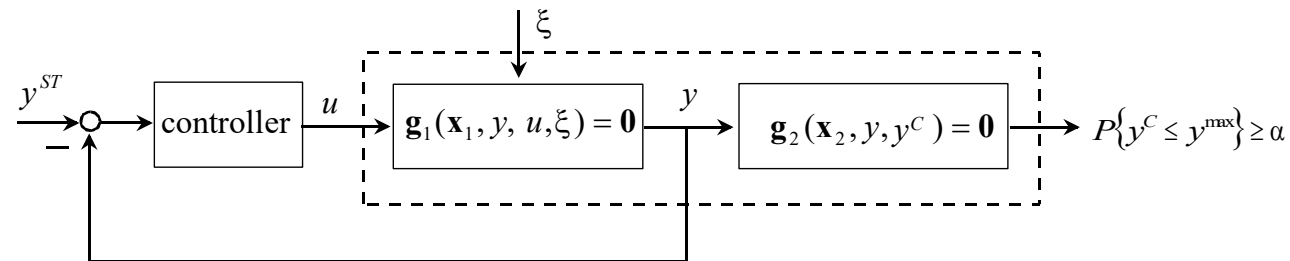

Uncertainty is to be compensated by the control loop. The constraint is **deterministic**.

Case 2: open loop

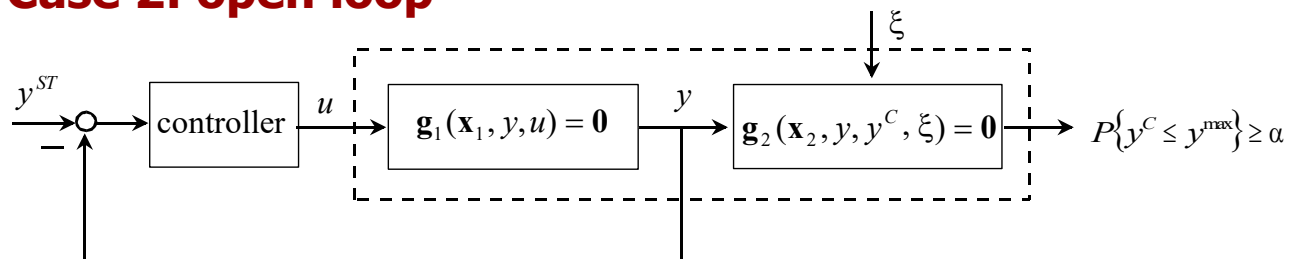

Uncertainty is outside the control loop. The constraint is to be held by an **open loop** chance constraint.

Case 3: closed-loop

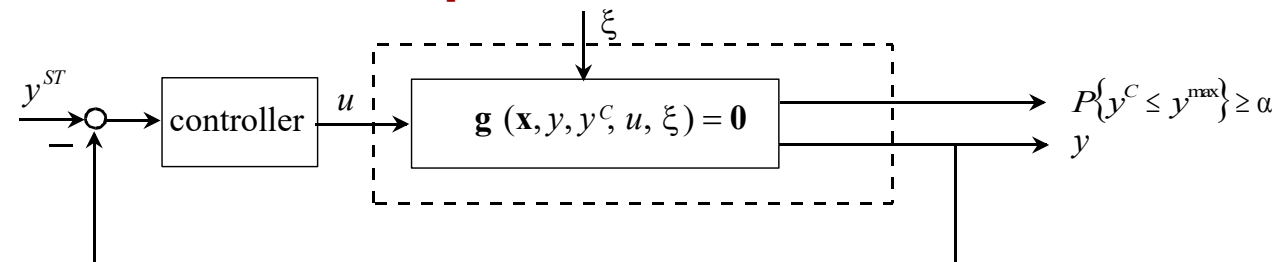

Uncertainty has impact on both y and y^C . The constraint has to be held by a **closed-loop** chance constraint.

Case 3 (1): open loop

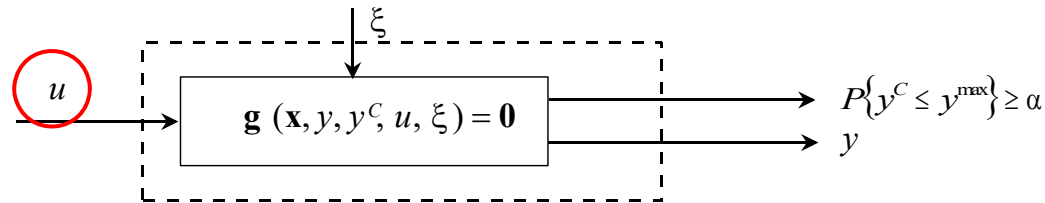

The decision variable is u , its constraint is deterministic.
The solution will be realized open loop.

$$\begin{aligned} & \min E[f(y, y^c, u)] \\ & s.t. \quad \mathbf{g}(\mathbf{x}, y, y^c, u, \xi) = \mathbf{0} \\ & \quad P\{y^c \leq y_{\max}^c\} \geq \alpha \\ & \quad u_{\min} \leq u \leq u_{\max} \end{aligned}$$

Case 3 (2): closed-loop

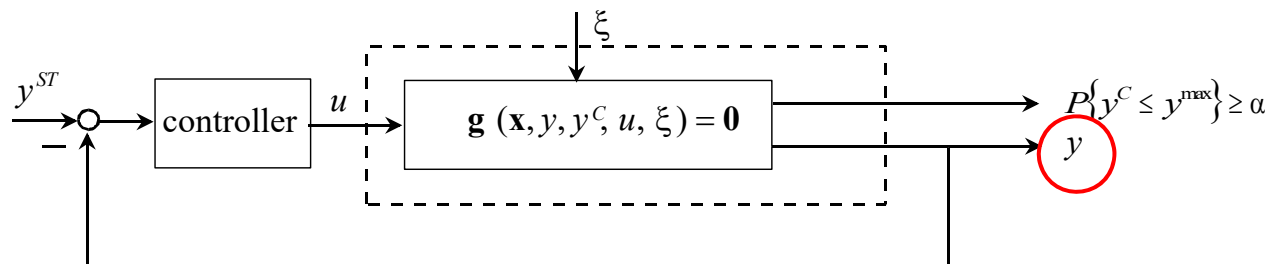

Since u is stochastic and has to be chance constrained,
decision variable is y . The solution will be realized by the
closed-loop setpoint.

$$\begin{aligned} & \min E[f(y, y^c, u)] \\ & s.t. \quad \mathbf{g}(\mathbf{x}, y, y^c, u, \xi) = \mathbf{0} \\ & \quad P\{y^c \leq y_{\max}^c\} \geq \alpha \\ & \quad P\{u_{\min} \leq u \leq u_{\max}\} \geq \alpha \\ & \quad y_{\min} \leq y \leq y_{\max} \end{aligned}$$

Closed-loop optimization of a distillation column

Process description:

- ▶ Separation of a water-methanol mixture
- ▶ Tray column with 20 trays
- ▶ Operation at atmospheric pressure

- ▶ Bottom temperature control
- ▶ Reflux ratio control

Uncertain variables:

- ▶ Tray efficiency
- ▶ Feed properties
 - ▶ Temperature
 - ▶ Volume flow rate
 - ▶ Methanol composition

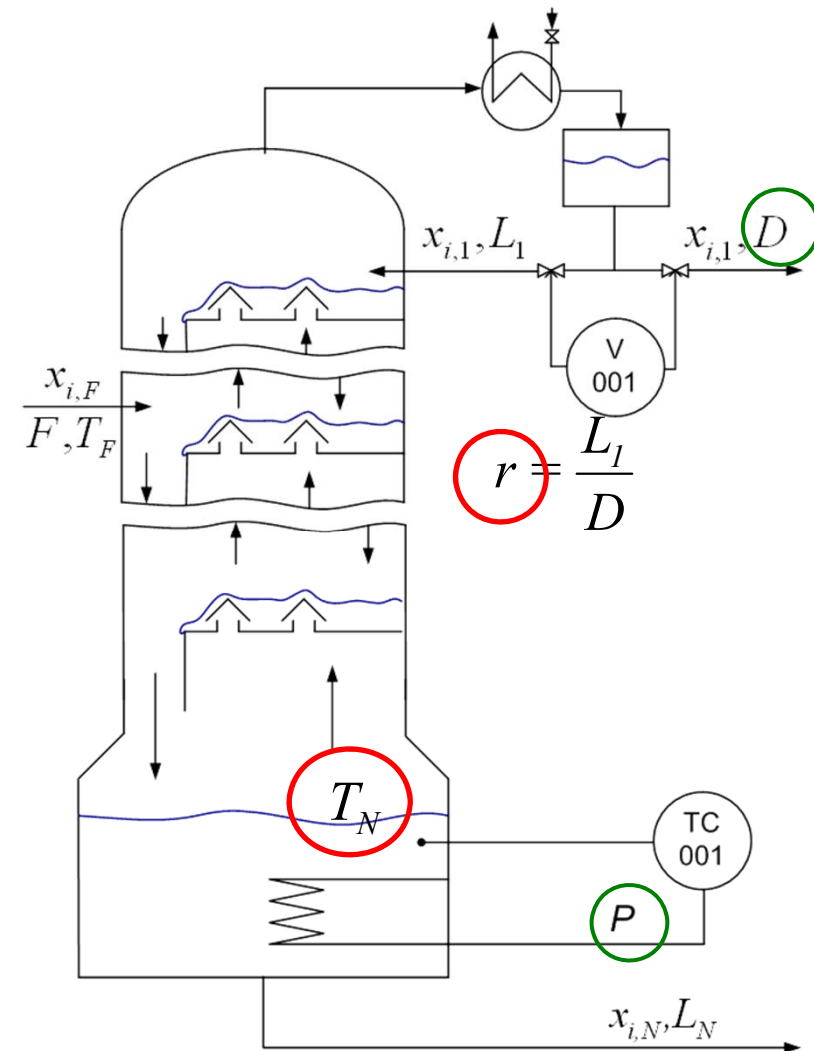

Aim of the Optimization:

- ▶ Minimization of the bottom heating energy (operating costs)
- ▶ Through minimizing the bottom temperature

Decision variables (setpoints):

- ▶ Bottom temperature T_N
- ▶ Reflux ratio r

Constraints:

- ▶ Distillate methanol composition: $x_{11} \geq 0,99$ mol/mol
- ▶ Distillate flow rate: $D \geq 6$ l/h
- ▶ Bottom heating energy: $0 \leq P \leq 6,8$ kW

Problem formulation:

$$\min T_N$$

$$s.t. \quad \mathbf{g}(\bullet) = \mathbf{0}$$

$$P\{x_{11} \geq 0,99 \text{ mol/mol}\} \geq \alpha_{x_{11}}$$

$$P\{D \geq 6 \text{ l/h}\} \geq \alpha_D$$

$$P\{0 \leq P \leq 6,8 \text{ kW}\} \geq \alpha_H$$

$$90 \text{ }^\circ\text{C} \leq T_N \leq 100 \text{ }^\circ\text{C}$$

$$1,0 \leq r \leq 6,0$$

Closed-loop optimization of a distillation column

Comparison of **stochastic** and **deterministic** results

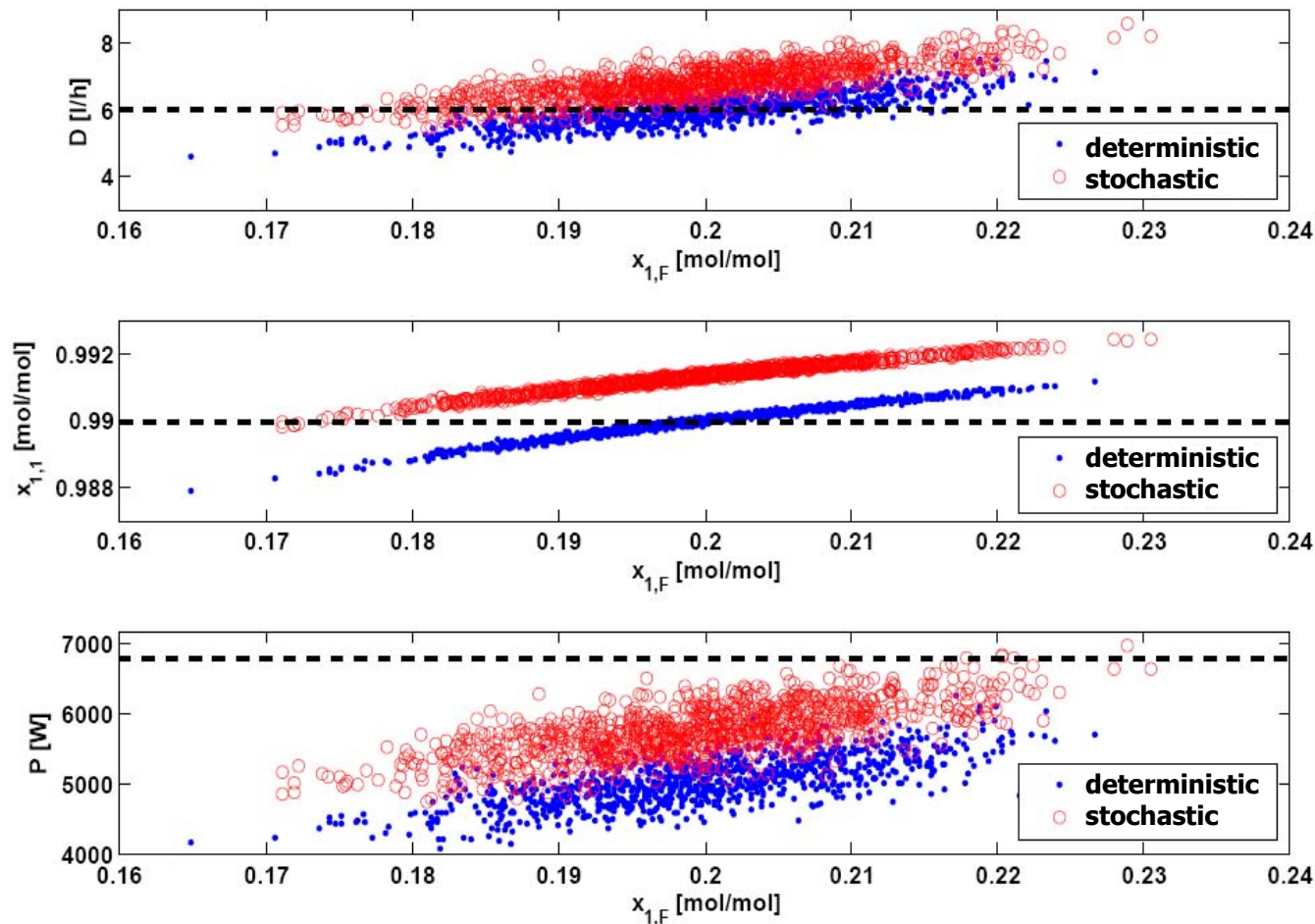

Probability of satisfying constraints:

	sto.	det.
D	95,52	49,40
$x_{1,1}$	99,72	50,00
P	99,57	100,00
α^{sim}	95,00	40,14

Objective function value:

	sto.	det.
T_N (°C)	96,16	92,30
$E(P)$ kW	5,71	5,04

Application to a process design optimization problem

Challenges:

- Distributions of uncertain variables are unknown.
- They are given in certain intervals.
- For safety consideration, a 100% reliability must be guaranteed.
- Design has to be feasible as well as optimal.
- The feasible region is to be identified for design.

For example:

$$g_1 = 0.08 u^2 - \xi_1 - \frac{1}{20} \xi_2 + \frac{1}{5} d_1 - 13 \leq 0$$

$$g_2 = -u - \frac{1}{3} \xi_1^{1/2} + \frac{1}{20} d_2 + \frac{1}{5} d_1 + 11 \frac{1}{3} \leq 0$$

$$g_3 = \exp(0.21 u) + \xi_1 + \frac{1}{20} \xi_2 - \frac{1}{5} d_1 - \frac{1}{20} d_2 - 11 \leq 0$$

- **Design Variables:** d_1, d_2
- **Uncertain Variables:**
 $2 \leq \xi_1 \leq 4, 2 \leq \xi_2 \leq 4$
- **Control Variable:** u

What is the feasible region for design?

Application to a process design optimization problem

Probability maximization problem

$$\max_{\mathbf{u}, \alpha} \alpha$$

$$\text{s.t. } P\{g_l(\mathbf{u}, \xi, \hat{\mathbf{d}}) \leq 0\} \geq \alpha, \quad l=1, \dots, L$$

$$\mathbf{u}_{\min} \leq \mathbf{u} \leq \mathbf{u}_{\max}$$

Feature: Feasible region over 100% reliability is not dependent on distributions!

Reliability levels vs. different design

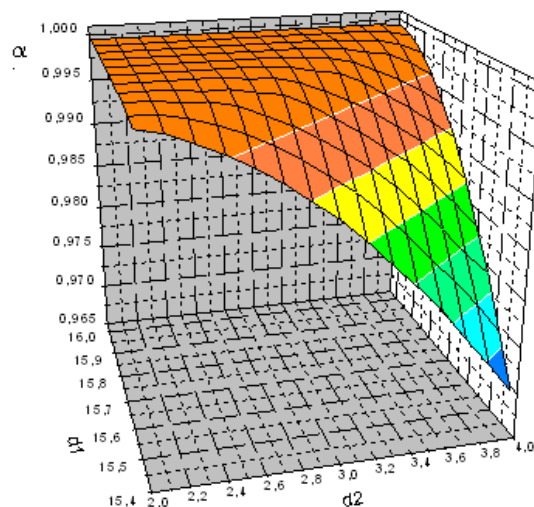

Feasible region under uniform distribution

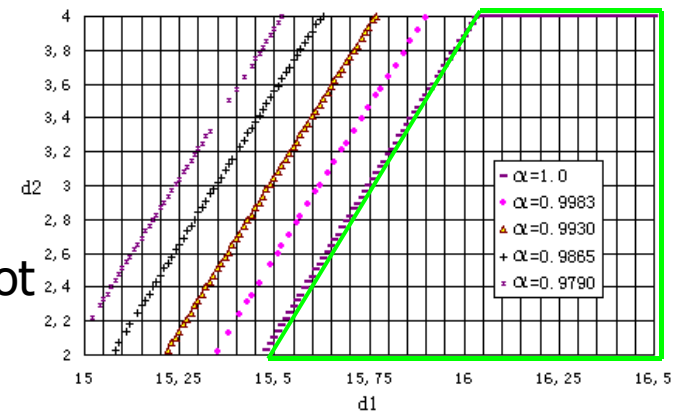

Feasible region under normal distribution

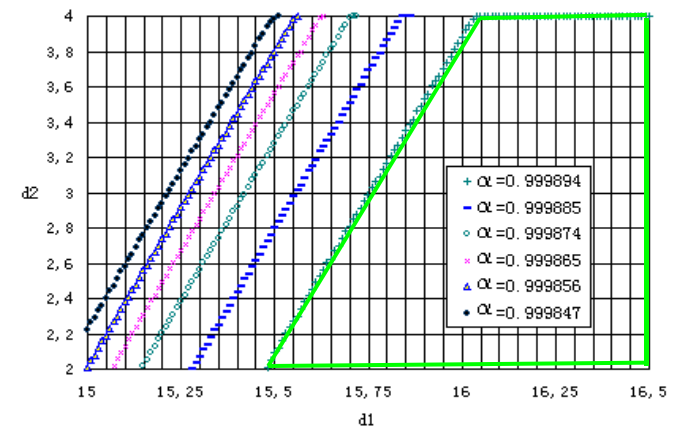

Nonlinear dynamic problem

$$\begin{aligned} \min \quad & f(\mathbf{x}, \mathbf{u}, \xi) \\ \text{s.t.} \quad & \mathbf{g}(\dot{\mathbf{x}}, \mathbf{x}, \mathbf{u}, \xi) = \mathbf{0}, \quad \mathbf{x}(t_0) = \mathbf{x}_0 \\ & \mathbf{y} = \mathbf{h}(\mathbf{x}, \mathbf{u}, \xi) \\ & \mathbf{y}_{\min} \leq \mathbf{y} \leq \mathbf{y}_{\max} \\ & \mathbf{u}_{\min} \leq \mathbf{u} \leq \mathbf{u}_{\max} \\ & t_0 \leq t \leq t_f \end{aligned}$$

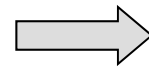

The chance constrained problem

$$\begin{aligned} \min \quad & E[f(\mathbf{x}, \mathbf{u}, \xi)] + \omega D[f(\mathbf{x}, \mathbf{u}, \xi)] \\ \text{s.t.} \quad & P\{y_i^{\min} \leq y_i(\mathbf{u}, \xi) \leq y_i^{\max}, i = 1, \dots, I\} \geq \alpha \\ \text{or} \quad & P\{y_i^{\min} \leq y_i(\mathbf{u}, \xi) \leq y_i^{\max}\} \geq \alpha_i, \quad i = 1, \dots, I \\ & \mathbf{u}_{\min} \leq \mathbf{u} \leq \mathbf{u}_{\max} \end{aligned}$$

Solution strategy:

- Discretization of the dynamic system in time intervals
- Transformation into a NLP problem
- Probability and gradient computation using the inverse mapping
- Solution of the NLP with the sequential approach

Aim of the Optimization:

- ▶ Minimization of oscillations of the outflow $u(t)$

Uncertain variables:

- ▶ Feed flow rate $F(t)$
- ▶ Feed concentration $C_0(t)$

Constraints:

- ▶ Volume $V_{\min} \leq V(t) \leq V_{\max}$
- ▶ Concentration $C_{\min} \leq C(t) \leq C_{\max}$

Model equations:

$$V(k) = V(k-1) + F(k-1) - u(k-1)$$

$$C(k) = C(k-1) + \frac{F(k-1)}{V(k)} [C_0(k-1) - C(k-1)]$$

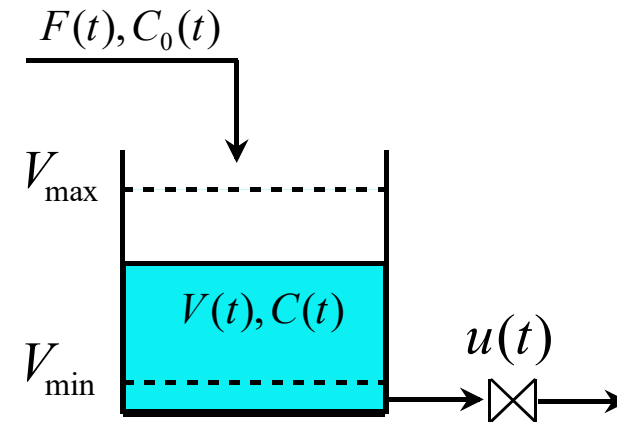

Chance constrained NMPC:

$$\begin{aligned} \min \quad & \sum_{j=0}^{N-1} [u(k+j) - u(k+j-1)]^2 \\ \text{s.t.} \quad & P\{V_{\min} \leq V(k+j) \leq V_{\max}\} \geq \alpha_1 \\ & P\{C_{\min} \leq C(k+j) \leq C_{\max}\} \geq \alpha_2 \\ & u_{\min} \leq u(k+j-1) \leq u_{\max} \\ & j = 1, \dots, N \end{aligned}$$

Variables in the time horizon:

random: $\mathbf{F} = [F(k) \cdots F(k+N-1)]^T$
 $\mathbf{C}_0 = [C_0(k) \cdots C_0(k+N-1)]^T$

states: $\mathbf{V} = [V(k+1) \cdots V(k+N)]^T$
 $\mathbf{C} = [C(k+1) \cdots C(k+N)]^T$

control: $\mathbf{u} = [u(k) \cdots u(k+N-1)]^T$

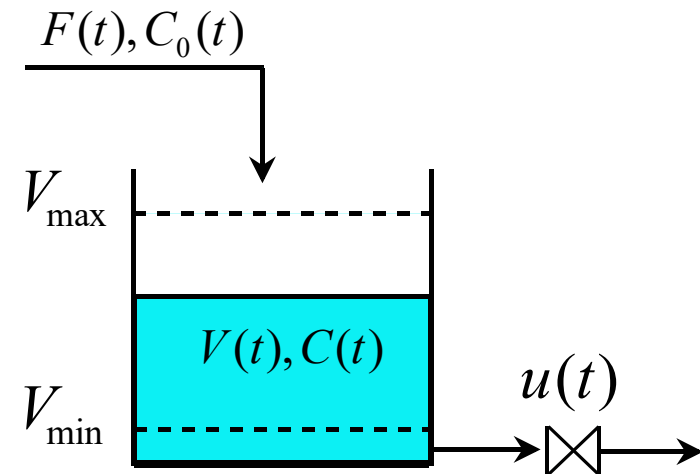

Inverse mapping: $P\{V_{\min} \leq V(k+j) \leq V_{\max}\} = P\{F^{\min}(k+j-1) \leq F(k+j-1) \leq F^{\max}(k+j-1)\}$

since $F(t) \uparrow \Rightarrow V(t) \uparrow$

$$= \int_{-\infty}^{\infty} dF(k) \cdots \int_{-\infty}^{\infty} dF(k+j-1) \int_{F^{\min}(k+j-1)}^{F^{\max}(k+j-1)} \rho(\mathbf{F}) dF(k+j-1)$$

where the bounds will be gained from the model equations:

$$V_{\min} = V(k) + \sum_{i=0}^{j-2} F(k+i) + F^{\min}(k+j-1) - \sum_{i=0}^{j-1} u(k+i)$$

$$V_{\max} = V(k) + \sum_{i=0}^{j-2} F(k+i) + F^{\max}(k+j-1) - \sum_{i=0}^{j-1} u(k+i)$$

Chance constrained nonlinear MPC (example)

The realized profiles of the stochastic MPC

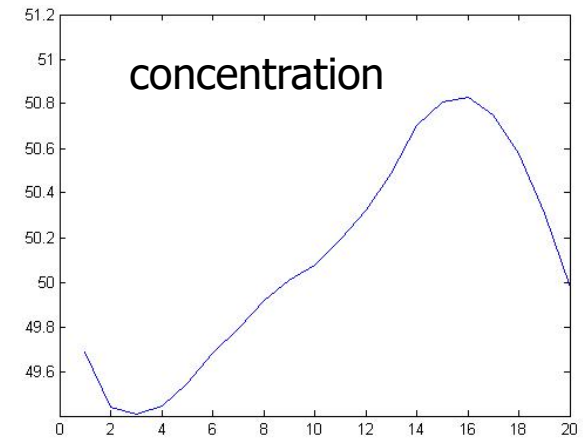
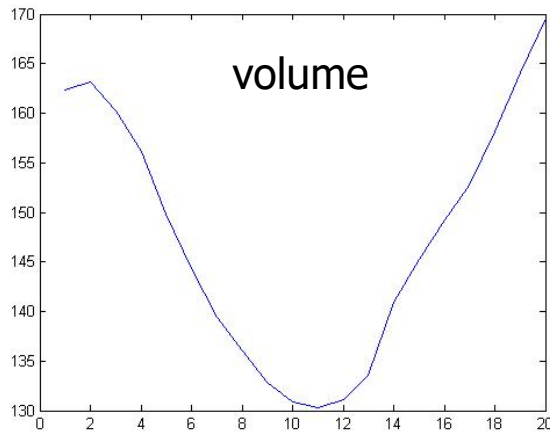
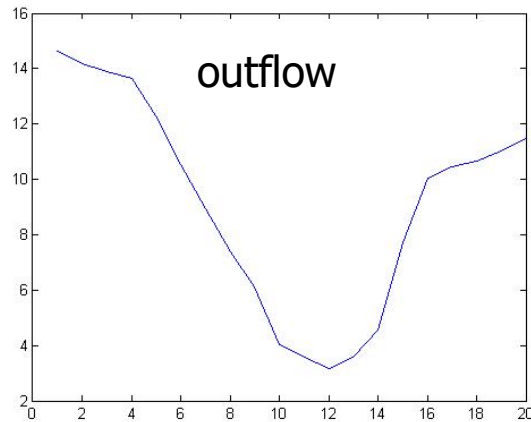

Monte-Carlo simulation based on the realized profiles

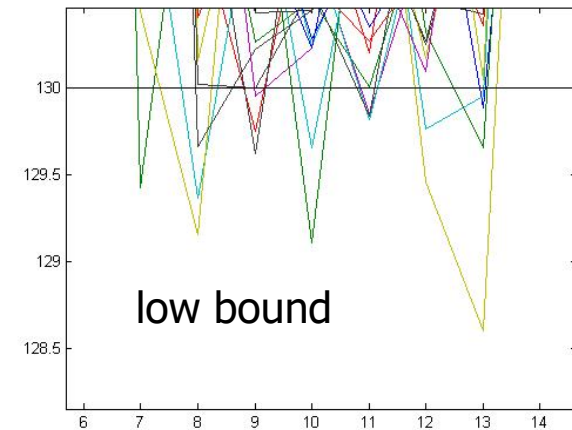
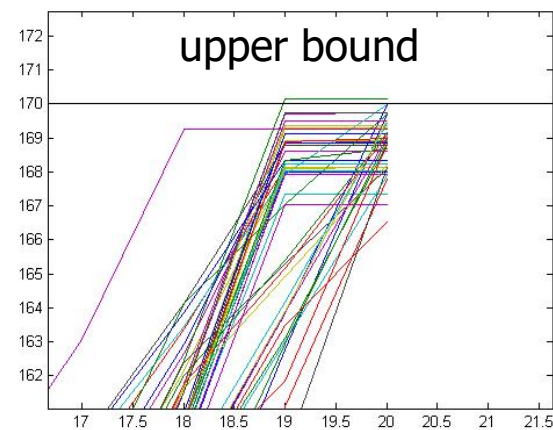
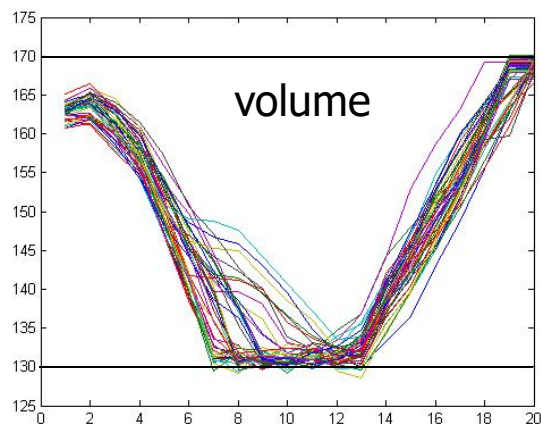

Optimization of operation policies for a reactive semi-batch distillation process

Chemical Reaction:

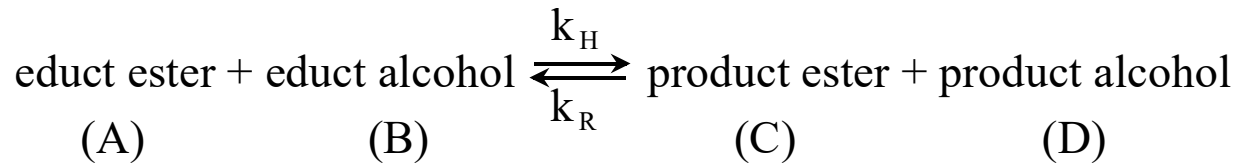

Aim of the Optimization:

Minimization of the batch time

Uncertain Variables:

- Kinetic parameters
- Tray efficiency
- Initial charge

Product Specifications:

- Product alcohol concentration $\geq 98\%$
- Educt ester concentration $\leq 2\%$

Optimization Variables:

- Reflux flow rate policy
- Educt alcohol dosage policy

A nonlinear dynamic optimization problem under chance constraints

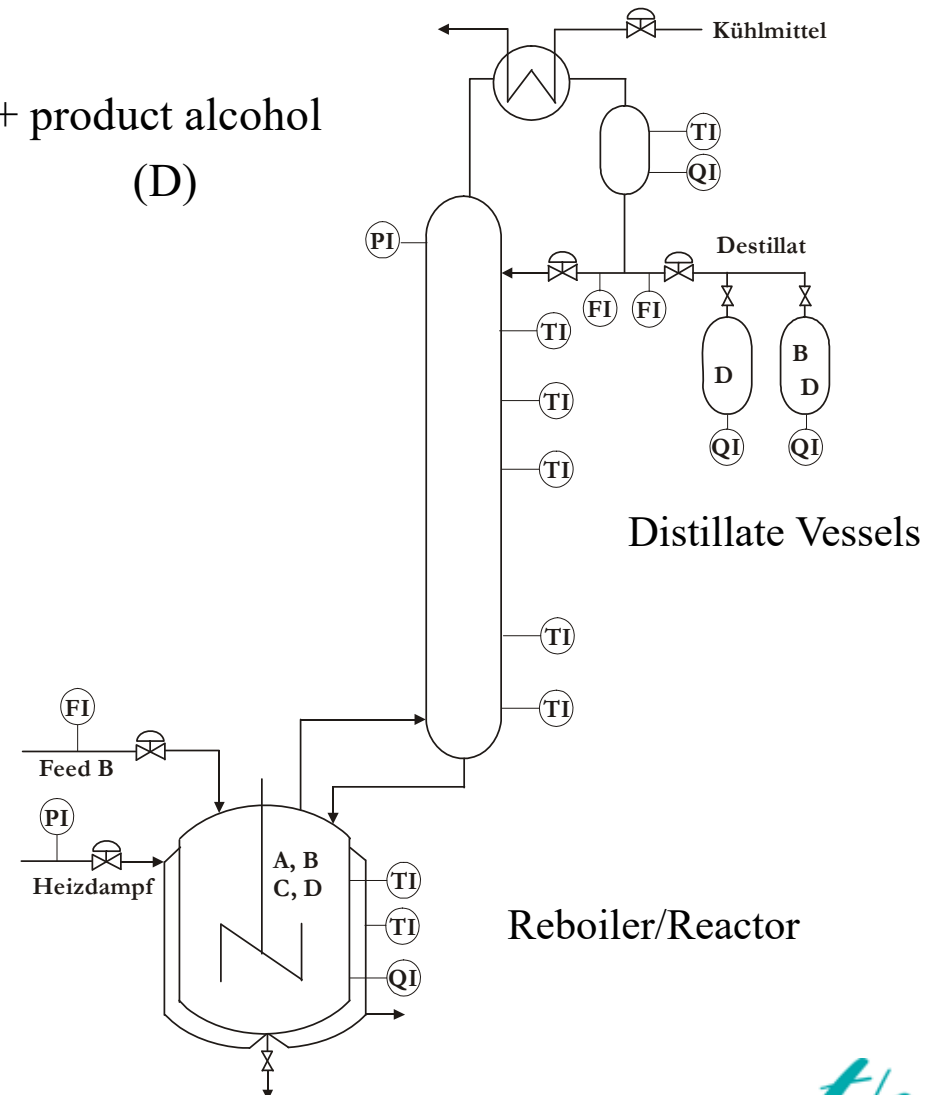

The optimization results

Product concentration based on **deterministic** Optimization

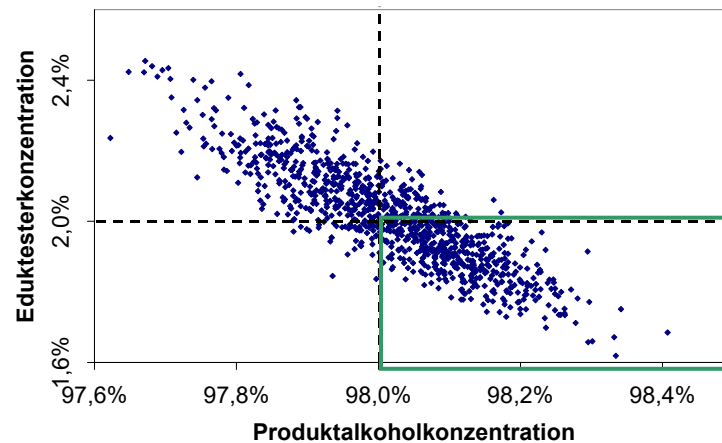

By realizing the deterministic optimal policy there will be a **50%** probability to violate the product specifications.

Product concentration based on **stochastic** Optimization

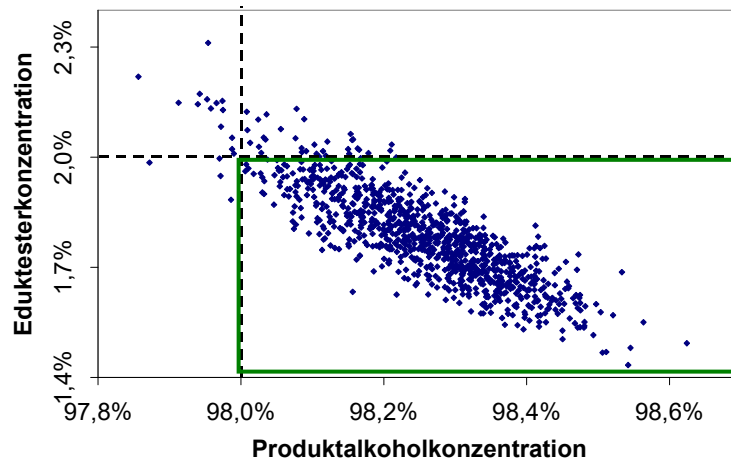

By realizing the stochastic optimal policy there will be only **4%** probability (as desired) to violate the product specifications.

Chance constrained optimization and control:

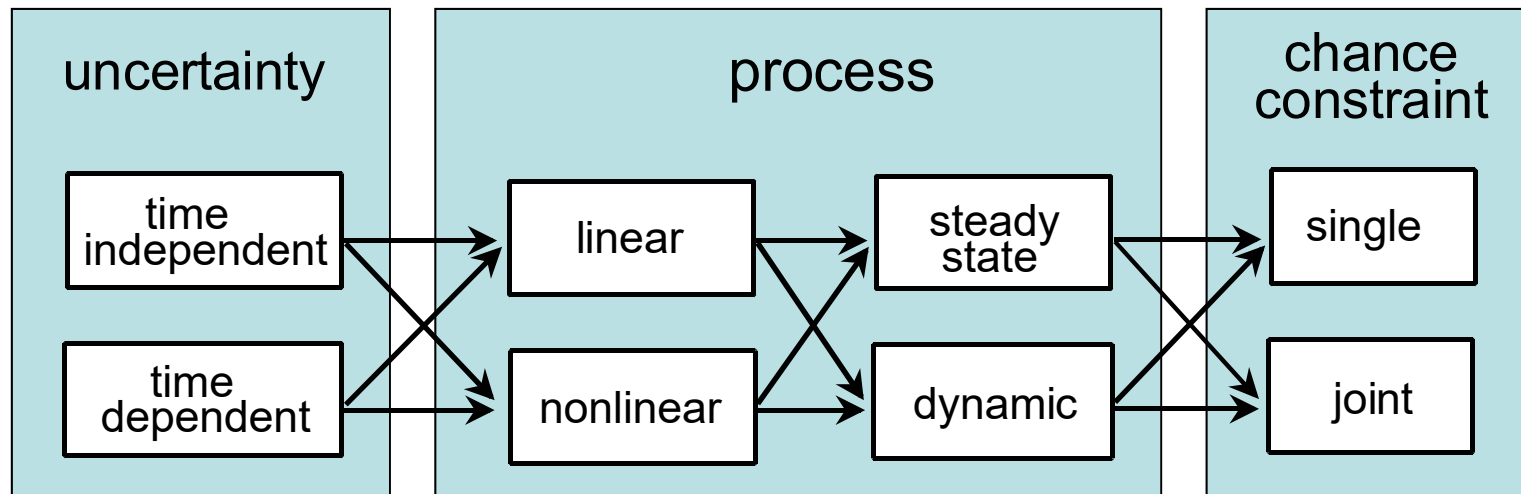

- ▶ **Consider different distribution of uncertainties**
- ▶ **Consider stochastic objective functions**
- ▶ **Consider mixed-integer problems**
- ▶ **Reduce the computation time**

- ▶ The process industry nowadays uses deterministic optimization approaches.
- ▶ Off-line, on-line process optimization is being carried out.
- ▶ Challenging task: Solution of large-scale, complex optimization problems under various uncertainties.

New Solution Approach

- ▶ General Concept to consider **uncertain** operating conditions as well as **uncertain** model parameters.
- ▶ Solve the problem with stochastic programming under chance constraints.
- ▶ Application to different optimization tasks in the process industry.
- ▶ The solution provides **optimal** as well as **reliable** decisions.

Future work:

- ▶ Application to large-scale problems
- ▶ On-line optimization under uncertainty

Acknowledgement

Research Coworkers:

- ▶ Moritz Wendt (TU Berlin)
- ▶ Harvey Arellano-Garcia (TU Berlin)
- ▶ Walter Martini (TU Berlin)
- ▶ Ri Hai (TU Berlin)
- ▶ Thomas Flemming (TU Ilmenau)
- ▶ Michael Klöppel (TU Ilmenau)
- ▶ Rene Henrion (WIAS Berlin)
- ▶ Andris Möller (WIAS Berlin)
- ▶ Werner Römisch (HU Berlin)
- ▶ Lei Xie (Zhejiang Uni)
- ▶ Martin Bartl (TU Ilmenau)
- ▶ Abebe Geletu (TU Ilmenau)

Financial Support:

- ▶ DFG-Program: On-line Optimization of Large-scale Systems
- ▶ DFG-Project WO565/12-1; 12-2
- ▶ DFG-Project LI806/4-1; 4-2; 4-3
- ▶ DFG-Project LI806/8-1; 8-2
- ▶ Max-Buchner-Research Scholarship
- ▶ Sandwich-Program of TU Berlin

References

- ▶ Li, P.; Arellano-Garcia, H.; Wozny, G., Chance constrained programming approach to process optimization under uncertainty, *Computers and Chemical Engineering*, 32(2008), 25-45.
- ▶ Th. Flemming; M. Bartl; P. Li, Set-point optimization for closed-loop control systems under uncertainty, *Industrial & Engineering Chemistry Research*, 46(2007), 4930-4942.
- ▶ Lei, X.; Li, P.; Wozny, G., Chance constrained nonlinear model predictive control, *Lecture Notes in Control and Information Sciences*, 358(2007), 295-304.
- ▶ Li, P.; Wendt, M.; Wozny, G., Optimal planning for chemical engineering processes under uncertain market conditions, *Chemical Engineering & Technology*, 27(2004), 641-651.
- ▶ Arellano-Garcia, H.; Martini, W.; Wendt, M.; Li, P.; Wozny, G., Chance constrained batch distillation process optimization under uncertainty, *International Symposium on Foundations of Computer-Aided Process Operation*, Coral Springs, Florida, January 12-15, 2003, Proceedings pp. 609-612.
- ▶ Wendt, M.; Li, P.; Wozny, G., Nonlinear chance constrained process optimization under uncertainty, *Industrial & Engineering Chemistry Research*, 41(2002), 3621-3629.
- ▶ Li, P.; Wendt, M.; Arellano-Garcia, H.; Wozny, G., Optimal operation of distillation processes under uncertain inflow streams accumulated in a feed tank, *AIChE Journal*, 48(2002), 1198-1211.
- ▶ Li, P.; Wendt, M.; Wozny, G., A probabilistically constrained model predictive controller, *Automatica*, 38(2002), 1171-1176.
- ▶ Li, P.; Wendt, M.; Wozny, G., Robust model predictive control under chance constraints, *Computers & Chemical Engineering*, 24(2000), 829-834.



Many thanks for your attention !

Welcome to Ilmenau !